

TECHNICAL MANUAL

**OPERATOR, UNIT AND DIRECT
SUPPORT
MAINTENANCE MANUAL
FOR**

**TENT, GENERAL
PURPOSE**

**SMALL NSN 8340-00-470-2335
MEDIUM NSN 8340-00-482-3963
LARGE NSN 8340-00-470-2342**

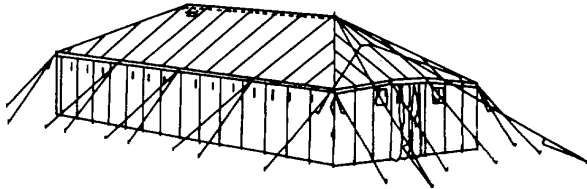

**EQUIPMENT DESCRIPTION
AND DATA
PAGE 1-2**

**OPERATOR PMCS
PAGE 2-16**

**OPERATOR MAINTENANCE
PROCEDURES
PAGE 3-3**

**SERVICE UPON RECEIPT
PAGE 4-2**

**UNIT PMCS
PAGE 4-21**

**UNIT MAINTENANCE
PROCEDURES
PAGE 4-24**

**MAINTENANCE ALLOCATION
CHART
PAGE B-1**

This copy is a reprint which includes current pages from Changes 1 through 4.

Approved for public release; distribution is unlimited.

***This manual supersedes TM 10-8340-211-13, 29 September 1972.**

**HEADQUARTERS, DEPARTMENTS OF THE ARMY AND AIR FORCE
16 SEPTEMBER 1990**

WARNING

DANGEROUS CHEMICALS

are used in the protective coating materials for the tent.

DEATH

or serious injury

can result if personnel fail to observe the following safety precautions.

Be sure serviceable fire extinguishers are near, and ready for use.

Do not smoke or allow open flame near the wet solution. When application is by either brush or spray, fumes are highly flammable. When some accidentally gets on the skin, stop, wash it away immediately with warm soapy water. Always wear a respirator when solution is being sprayed on.

Never spray while equipment used for food and drink is in the area. Fallout can be dangerous as well as distasteful.

a/(b blank)

CHANGE
NO. 5

HEADQUARTERS
DEPARTMENT OF THE ARMY
WASHINGTON, DC, 30 SEPTEMBER 2005

TECHNICAL MANUAL
OPERATOR, UNIT AND DIRECT SUPPORT MAINTENANCE MANUAL
FOR
TENT, GENERAL PURPOSE

SMALL NSN: 8340-00-470-2335
MEDIUM NSN: 8340-00-482-3963
LARGE NSN: 8340-00-470-2342

DISTRIBUTION STATEMENT A: Approved for public release; distribution is unlimited.

TM 10-8340-211-13, dated 16 September 1990, is changed as follows:

1. File this sheet in the front of the manual for reference.
2. This change implements Army Maintenance Transformation and changes the Maintenance Allocation Chart (MAC) to support Field and Sustainment Maintenance.
3. New or updated text is indicated by a vertical bar in the outer margin.
4. Added illustrations are indicated by a vertical bar adjacent to the figure number. Changed illustrations are indicated by a miniature hand adjacent to the updated area and a vertical bar adjacent to the figure number.
5. Remove old pages and insert new pages as indicated below:

Remove Pages

B-1 – B-4

2028

Insert Pages

A/(B blank)

B-1 – B-5/(B-6 blank)

Electronic 2028 Instructions/blank

Sample 2028 – Front/Back

2028 – Front/Back

2028 – Front/Back

2028 – Front/ Back

ARMY TM 10-8340-211-13
AIR FORCE TO 35E5-1-101
C5

By Order of the Secretaries of the Army, and Air Force:

PETER J. SCHOOMAKER
General, United States Army
Chief of Staff

Official:



*Administrative Assistant to the
Secretary of the Army*
0525009

MICHAEL E. RYAN
GENERAL, USAF
Chief of Staff

Official:

GEORGE T. BABBETT
General, USAF
Commander, Air Force Materiel Command

DISTRIBUTION:

To be distributed in accordance with initial distribution IDN 251756, requirements for
TM 10-8340-211-13.

CHANGE

HEADQUARTERS
DEPARTMENTS OF THE ARMY AND AIR FORCE
WASHINGTON, DC., 13 January 1995

NO. 4

Operator, Unit and Direct Support Maintenance Manual
for
TENT, GENERAL PURPOSE
SMALL, NSN 8340-00-470-2335
MEDIUM, NSN 8340-00-482-3963
LARGE, NSN 8340-00-470-2342

DISTRIBUTION STATEMENT A: Approved for public release; distribution is unlimited

TM 10-8340-211-13/TO 35E5-1-101, 16 September 1990, is changed as follows:

1. Remove and insert pages as indicated below. New or changed text material is indicated by a vertical bar in the margin. An illustration change is indicated by a miniature pointing hand.

Remove pages	Insert pages
B-3 and B-4 B-5/(B-6 blank)	B-3 and B-4 -----

2. Retain this sheet in front of manual for reference purposes.

By Order of the Secretaries of the Army and Air Force:

GORDON R. SULLIVAN
General, United States Army
Chief of Staff

Official:

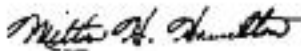

MILTON H. HAMILTON
Administrative Assistant to the
Secretary of the Army
07843

MERRILL A. McPEAK
General, USAF
Chief of Staff

RONALD W. YATES
General, USAF
Commander, Air Force Materiel Command

DISTRIBUTION:

To be distributed in accordance with DA Form 12-25-E, block no. 1756, requirements for TM 10-8340-211-13.

ARMY TM 10-8340-211-13
AIR FORCE TO 35E5-1-101
C 3

CHANGE

NO. 3

HEADQUARTERS
DEPARTMENTS OF THE ARMY, AND AIR FORCE
WASHINGTON, D.C., 29 April 1994

Operator, Unit and Direct Support Maintenance Manual

TENT, GENERAL PURPOSE
SMALL, NSN 8340-00-470-2335
MEDIUM, NSN 8340-00-482-3963
large, nsn 8340-00-470-2342

DISTRIBUTION STATEMENT A: Approved for public release; distribution is unlimited.

TM 10-8340-211-13/TO 35E5-1-101, 16 September 1990, is changed as follows:

1. Remove and insert pages as indicated below. New or changed text material is indicated by a vertical bar in the margin. An illustration change is indicated by a miniature pointing hand.

Remove pages

i and ii
4-27 and 4-28
4-41 and 4-42
C-1 and C-2
E-1 and E-2

Insert pages

i and ii
4-27 and 4-28
4-41 and 4-42
C-1 and C-2
E-1 and E-2

2. Retain this sheet in front of manual for reference purposes.

By Order of the Secretary of the Army:

Official:

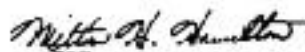

MILTON H. HAMILTON
Administrative Assistant to the
Secretary of the Army
07068

GORDON R. SULLIVAN
General, United States Army
Chief of Staff

DISTRIBUTION:

To be distributed in accordance with DA Form 12-25-E, block no. 1756, requirements for TM 10-8340-211-13.

CHANGE
NO. 2

HEADQUARTERS,
DEPARTMENTS OF THE ARMY, AND AIR FORCE
WASHINGTON, D.C., 30 December 1993

Operator, Unit and Direct Support Maintenance Manual

TENT, GENERAL PURPOSE
SMALL, NSN 8340-00-470-2335
MEDIUM, NSN 8340-0-482-3963
LARGE, NSN 8340-0-470-2342

DISTRIBUTION STATEMENT A: Approved for public release; distribution is unlimited

TM 10-8340-211-13/TO 35E5-1-101, 16 September 1990, is changed as follows:

1. Remove and insert pages as indicated below. New or changed text material is indicated by a vertical bar in the margin. An illustration change is indicated by a miniature pointing hand.

Remove pages	Insert pages
i and ii	i and ii
1-1 and 1-2	1-1 and 1-2
4-3 and 4-4	4-3 and 4-4
4-7 through 4-12	4-7 through 4-12
F-1/(F-2 blank)	F-1/(F-2 blank)

2. Retain this sheet in front of manual for reference purposes.

By Order of the Secretaries of the Army and Air Force:

Official:

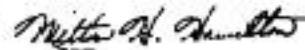

MILTON H. HAMILTON
Administrative Assistant to the
Secretary of the Army
00550

GORDON R. SULLIVAN
General, United States Army
Chief of Staff

Official:

RONALD W. YATES
General, USAF
Commander, Air Force Materiel Command

MERRILL A. McPEAK
General, USAF
Chief of Staff

DISTRIBUTION:

To be distributed in accordance with DA Form 12-25-E, block no. 1756, requirements for TM 10-8340-211-13

CHANGE
NO. 1

HEADQUARTERS,
DEPARTMENTS OF THE ARMY AND AIR FORCE
WASHINGTON, D.C., 30 September 1991

Operator, Unit and Direct Support Maintenance Manual

TENT, GENERAL PURPOSE
SMALL, NSN 83400470-2335
MEDIUM, NSN 8340-00-482-3963
LARGE, NSN 8340-00-70-2342

Approved for public release; distribution is unlimited

TM 10-8340-211-13/TO 35E5-1-101, 16 September 1990 is changed as follows:

1. Remove and insert pages as indicated below. New or changed text material is indicated by a vertical bar in the margin. An illustration change is indicated by a miniature pointing hand.

Remove pages

i and ii
1-1 and 1-2
2-27 and 2-28

3-1 and 3-2
4-7 and 4-8
4-25 and 4-26
C-1 through C-4
E-1 and E-2

Insert pages

i and ii
1-1 and 1-2
2-27 and 2-28
2-28.1/(2-28.2 blank)
3-1 and 3-2
4-7 and 4-8
4-25 and 4-26
C-1 through C-4
E-1 and E-2

2. Retain this sheet in front of manual for reference purposes.

By Order of the Secretaries of the Army and Air Force:

CARL E. VUONO
General, United States Army
Chief of Staff

Official:

PATRICIA P. HICKERSON
Colonel, United States Army
The Adjutant General

MERRILL A. McPEAK
General USAF
Chief of Staff

Official:

CHARLES C. McDONALD
General, USAF
Commander, Air Force Logistics Command

DISTRIBUTION:

To be distributed in accordance with DA Form 12-25E, (qty rqr block no. 1756).

INSERT LATEST CHANGED PAGES. DESTROY SUPERSEDED PAGES.

LIST OF EFFECTIVE PAGES

NOTE: The portion of text affected by the changes is indicated by a vertical line in the outer margins of the page. Changes to illustrations are indicated by shaded or screened areas, or by miniature pointing hands. Zero in the "Change No." column indicates an original page.

Dates of issue for original and changed pages are:

Original .. 0 .. 16 September 1990
 Change .. 1 .. 30 September 1991
 Change .. 2 .. 30 December 1993
 Change .. 3 .. 29 April 1994
 Change .. 4 .. 13 January 1995
 Change .. 5 .. 30 September 2005

TOTAL NUMBER OF PAGES IN THIS PUBLICATION IS 152, CONSISTING OF THE FOLLOWING:

Page No.	Change No.	Page No.	Change No.
Title	0	4-12 - 4-24	0
a/(b blank)	0	4-25	1
i	3	4-26 - 4-27	0
ii - iv	0	4-28	3
1-0 - 1-1	0	4-29 - 4-40	0
1-2	2	4-41	3
1-3 - 1-6	0	4-42 - 4-47/(4-48 blank)	0
2-1 - 2-27	0	5-1 - 5-8	0
2-28	1	A-1/(A-2 blank)	0
2-28.1/(2-28.2 blank)	0	B-1 - B-5/(B-6 blank)	5
2-29/(2-30 blank)	0	C-1	0
3-1	1	C-2	3
3-2 - 3-5/(3-6 blank)	0	C-3	1
4-1 - 4-3	0	C-4	0
4-4	2	D-1 - D-2	0
4-5 - 4-6	0	E-1	0
4-7	1	E-2	3
4-8 - 4-11	2	F-1/(F-2 blank)	2
		Back Cover	0

**OPERATOR, UNIT, AND DIRECT SUPPORT
MAINTENANCE MANUAL FOR
TENT, GENERAL PURPOSE
SMALL NSN 8340-00-470-2335, MEDIUM NSN 8340-00-482-3963
LARGE NSN 8340-00-470-2342
Current as of 1 January, 1990**

REPORTING ERRORS AND RECOMMENDING IMPROVEMENTS

You can help improve this manual. If you find any mistakes or if you know of a way to improve these procedures, please let us know. Mail your letter or DA Form 2028 (Recommended Changes to Publications and Blank Forms), or DA Form 2028-2 located in the back of this manual directly to: Commander, US Army Aviation and Troop Command, ATTN: AMSAT-I-MP, 4300 Goodfellow Blvd., St. Louis, MO 63120-1798. A reply will be furnished directly to you.

AIR FORCE

For Air Force, submit AFTO Form 22 (Technical Order System Publication Improvement Report and Reply) in accordance with paragraph 6-5, Section VI, T.O. 00-5-1. Forward direct to prime ALC/MST.

DISTRIBUTION STATEMENT A: Approved for public release; distribution is unlimited.

TABLE OF CONTENTS

	Page
CHAPTER 1. INTRODUCTION	
Overview	1-1
Section I General Information	1-1
Section II Equipment Description and Data	1-2
Section III Principles of Operation.....	1-6
CHAPTER 2. OPERATING INSTRUCTIONS	
Overview	2-1
Section I Description and use of Operator's Controls.....	2-1
Section II Operator Preventive Maintenance Checks and Services (PMCS)	2-16
Section III Operating Under Usual Conditions.....	2-20
Section IV Operating Under Unusual Conditions.....	2-26
CHAPTER 3. OPERATOR MAINTENANCE INSTRUCTIONS	
Overview	3-1
Section I Lubrication Instructions	3-1
Section II Operator Troubleshooting.....	3-1
Section III Operator Maintenance Procedures	3-3

*This manual supersedes TM 10-8340-211-13/TO 35E5-1-101, dated 29 Sept 1972, including all changes.

TABLE OF CONTENTS (cont)

	Page
CHAPTER 4. UNIT MAINTENANCE INSTRUCTIONS	
Overview	4-1
Section I Repair Parts, Special Tools, and Support Equipment	4-1
Section II Service Upon Receipt	4-2
Section III Unit Preventive Maintenance Checks and Services (PMCS)	4-21
Section IV Unit Troubleshooting	4-22
Section V Unit Maintenance Procedures	4-24
Section VI Preparation for Shipment or Storage	4-40
CHAPTER 5. DIRECT SUPPORT MAINTENANCE	
Overview	5-1
Section I Repair Parts, Special Tools and Support Equipment	5-1
Section II Troubleshooting	5-1
Section III Direct Support Maintenance	5-2
APPENDIX A REFERENCES	A-1
APPENDIX B MAINTENANCE ALLOCATION CHART	B-1
APPENDIX C COMPONENTS OF END ITEM AND BASIC ISSUE ITEMS	C-1
APPENDIX D ADDITIONAL AUTHORIZATION LIST	D-1
APPENDIX E EXPENDABLE/DURABLE SUPPLIES AND MATERIALS LIST	E-1
APPENDIX F LIST OF MANUFACTURED/FABRICATED TENT LINES AND COVERS	F-1

LIST OF ILLUSTRATIONS

Figure Number	Title	Page
1-1	Tent, General Purpose.....	1-0
1-2	Small General Purpose Tent.....	1-3
1-3	Medium General Purpose Tent.....	1-4
1-4	Large General Purpose Tent.....	1-4
2-1	Small Tent, Door Closed.....	2-2
2-2	Tent Door Closed (Inside View)	2-4
2-3	Tent and Liner, Doors Open with Flaps Rolled and Tied	2-6
2-4	Ventilator Duct, Inside View/Outside View (Small Tent)	2-8
2-5	Roof Ventilator and Raps, Outside View	2-9
2-6	Stovepipe Opening Closed (Outside View)	2-10
2-7	Stovepipe Opening - Small Tent (Inside View).....	2-11
2-8	Double Door Entrance (Medium and Large Tents)	2-12

LIST OF ILLUSTRATIONS (cont)

Figure Number	Title	Page
2-9	Left and Right Screen Doors (Medium and Large Tents).....	2-13
2-10	Stovepipe Opening Open (Medium and Large Tents)	2-14
2-11	Windows (Large Tent)	2-15
2-12	Opening Tent Door (Small Tent).....	2-21
2-13	Opening Screen (Small Tent)	2-22
2-14	Opening Ventilator Duct (Small Tent)	2-23
2-15	Opening Ventilator Flap	2-23
2-16	Opening Doors (Medium and Large Tents)	2-24
2-17	Opening Screens (Medium and Large Tents).....	2-25
2-18	Opening Windows (Large Tent)	2-26
2-19	Opening Stovepipe Flaps	2-27
4-1	Small General Purpose Tent, Packed for Shipment.....	4-2
4-2	Ground Plan of Small General Purpose Tent (with Vestibule)	4-5
4-3	Erection of Small General Purpose Tent.....	4-6
4-4	Ground Plan of Medium General Purpose Tent	4-7
4-5	Erection of Medium General Purpose Tent	4-8
4-6	Ground Plan of Large General Purpose Tent	4-9
4-7	Erection of Large General Purpose Tent.....	4-10
4-8	Small Tent with Liner	4-12
4-9	Erection of Liner in Medium Tent.....	4-14
4-10	Folding Medium Tent Liners	4-15
4-11	Erecting Liner in Large Tent.....	4-16
4-12	Folding the Large Tent Liner.....	4-18
4-13	Joining Vestibule to Small Tent, or Two Small Tents in Tandem.....	4-19
4-14	Cross Section of Trench Around Tent	4-20
4-15	Trenching Around Tent	4-21
4-16	Tent Body	4-27
4-17	Ventilator Flap Line Replacement (Small Tent).....	4-28
4-18	Wood Toggles	4-29
4-19	Corner Hook	4-30
4-20	Grommets	4-31
4-21	Dual Eave, Corner and Guy Lines.....	4-33
4-22	Fairleads	4-34
4-23	Peak Plate	4-35
4-24	Ridge Plate.....	4-36
4-25	Slide Fasteners and Thongs	4-37
4-26	Vestibule	4-38
4-27	Folding the Small Tent.....	4-42
4-28	Folding the Medium Tent	4-44
4-29	Folding the Large Tent.....	4-46
5-1	Stovepipe Opening Shield	5-6
5-2	Cover for Medium Tent or Liner for Large Tent.....	5-8

LIST OF TABLES

Table Number	Title	Page
2-1	Operator Preventive Maintenance Checks and Services (PMCS)	2-18
3-1	Operator Troubleshooting	3-2
4-1	Unit Preventive Maintenance Checks and Services (PMCS).....	4-22
4-2	Unit Troubleshooting.....	4-23
F-1	List of Manufactured/Fabricated Tent Liners and Covers	F-1

HOW TO USE THIS MANUAL

This manual is designed to help you keep your general purpose tents in good operating condition. The front cover index is provided for quick reference to important information. There is also an index located in the final pages for use in locating specific items of information.

A warning page is located in the front of this manual. You should learn the warnings before performing any maintenance on the equipment.

Paragraphs in this manual are numbered by chapter and order of appearance within a chapter. A subject index appears at the beginning of each chapter listing sections that are included in that chapter. A more specific index is located at the beginning of each section to help you find the exact paragraph you are looking for.

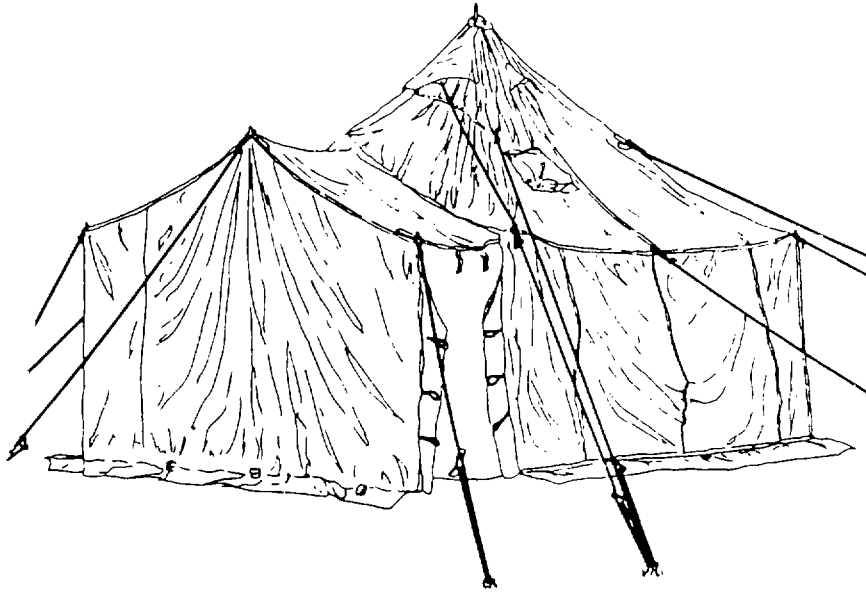

SMALL

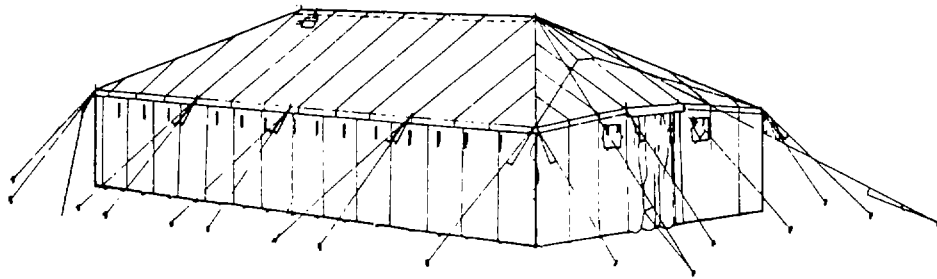

MEDIUM

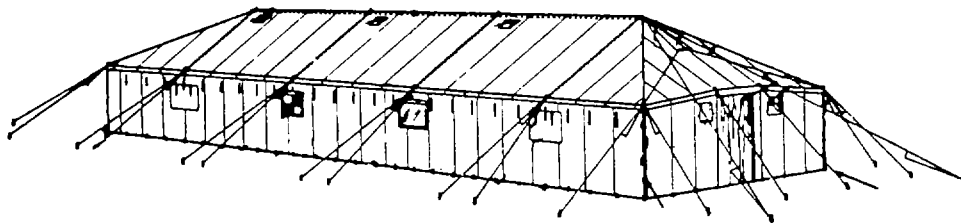

LARGE

Figure 1-1. Tent, General Purpose.

CHAPTER 1
INTRODUCTION

	Page
OVERVIEW	1-1
SECTION I. General Information	1-1
SECTION II. Equipment Description and Data	1-2
SECTION III. Principles of Operation.....	1-6

OVERVIEW

This chapter contains general information pertinent to the General Purpose Tents and describes the components to enhance the understanding of their use and function.

Section I. GENERAL INFORMATION

1-1. Scope.

a. Type of Manual. This technical manual includes operator, unit and direct support (DS) maintenance procedures for the three General Purpose Tents (small, medium, and large). Additional maintenance data relevant to a designated tent can be found in the applicable end item technical manual.

b. Equipment Name and Model Numbers. This technical manual covers the Tent, General Purpose, Small (NSN 8340-00-740-2335), Medium (NSN 8340-00-482-3963), and Large (NSN 8340-00-470-2342) (figure 1-1).

c. Purpose of Equipment. The General Purpose tents are designed to provide shelter, be easily portable and very durable when properly maintained.

1-2. Maintenance Forms and Records. Department of the Army forms and procedures used for equipment maintenance will be those prescribed by DA Pam 738-750, The Army Maintenance Management System (TAMMS). Refer to the latest issue of DA Pam 25-30 (Consolidated Index of Army Publications and Blank Forms) to determine if there are new editions, changes or additional publications pertaining to the equipment. Air Force personnel will use AFR 66-1 for maintenance reporting and TO-00-35D54 for unsatisfactory equipment reporting.

1-3. Destruction of Army Materiel to Prevent Enemy Use. Destruction of Army equipment to prevent enemy use shall be in accordance with TM 750-244-3.

1-4. Preparation for Shipment or Storage. Refer to paragraph 4-35 for shipment and storage preparation data.

1-5. Reporting of Equipment Improvement Recommendations (EIR).

a. Army. If your shelter needs improvement, let us know. Send us an EIR. You, the user, are the only one who can tell us what you don't like about your equipment. Let us know why you don't like the design or performance. Put it on an SF 368 (Quality Deficiency Report). Mail it to: Commander, U.S. Army Aviation and Troop Command, ATTN: AMSAT-I-MDO, 4300 Goodfellow Blvd., St. Louis, MO 63120-1798. We will send you a reply.

b. Air Force. Air Force personnel are encouraged to submit EIR's in accordance with AFR 900-4.

Section II. EQUIPMENT DESCRIPTION AND DATA

1-6. Characteristics, Capabilities and Features.

a. General. The outer fabric, or skin of each tent (figure 1-1), is a one-piece preformed body manufactured from 9.85 or 12.29 ounce duck material, treated for fire, water, weather, and mildew resistance. The tents are designed for use in tropical or temperate zones. With installation of a liner and/or a stove (TM 10-4500-200-13), General Purpose tents may be used effectively in colder climate. The liner is also effective in reducing heat from midsummer sun. Liners are not issued with the tents, but may be requisitioned separately when required.

b. Small General Purpose Tent. This is a hexagonal shaped pyramidal tent supported by telescopic poles at center, side eaves, and front or rear door eaves. Both front and rear doors are provided with a "lacing-flap" arrangement that permits erection of two tents in tandem, and the installation of a vestibule (para. 4-29), for additional warmth under extreme cold or windy conditions. Equipped with six ventilators, one stove pipe opening and the two doors, it is normally used as a command post, fire direction center, battalion aid station, or shelter for 10 individuals, their clothing and their equipment. For dimensions, refer to para. 1-8.

c. Medium General Purpose Tent. This tent is of rectangular shape, hip-roofed and supported by joined wood center poles, a jointed wood ridge pole, along with solid wood eaves and door poles. A liner is available for issue on request, when weather conditions make its use desirable. The tent is equipped with two doors (one at each end), door curtains, door screens, two ventilators (one at top of each end), and two stove pipe openings. The medium tent is designed for use in artillery operations, housing components of a field baker, or quarters for troops. It may also be used as a command post, fire support control center, mess hall, storage, or ward of a field hospital, etc. For dimensions, refer to para. 1-8.

d. Large General Purpose Tent. This tent is of rectangular shape, hip-roofed, and supported by jointed wood center poles, and solid wood eaves and door poles. A liner is also available on request. The tent is equipped with two doors (one at each end), door curtains, door screens, eight window assemblies (four on each side), two ventilators (one at top of each end), and three stove pipe openings. The large tent is designed for use as a hospital ward, surgical operating room, command post, fire direction center, or mess hall. It may also be used for storage, as an assembly tent, or quarters for troops. For dimensions, refer to para. 1-8.

1-7. Location and Description of Major Components. Figures 1-2, 1-3 and 1-4, locate and illustrate the major components of each size tent. Further discussion of operating components is given in Chapter 2, Section I Description and Use of Operator's Controls.

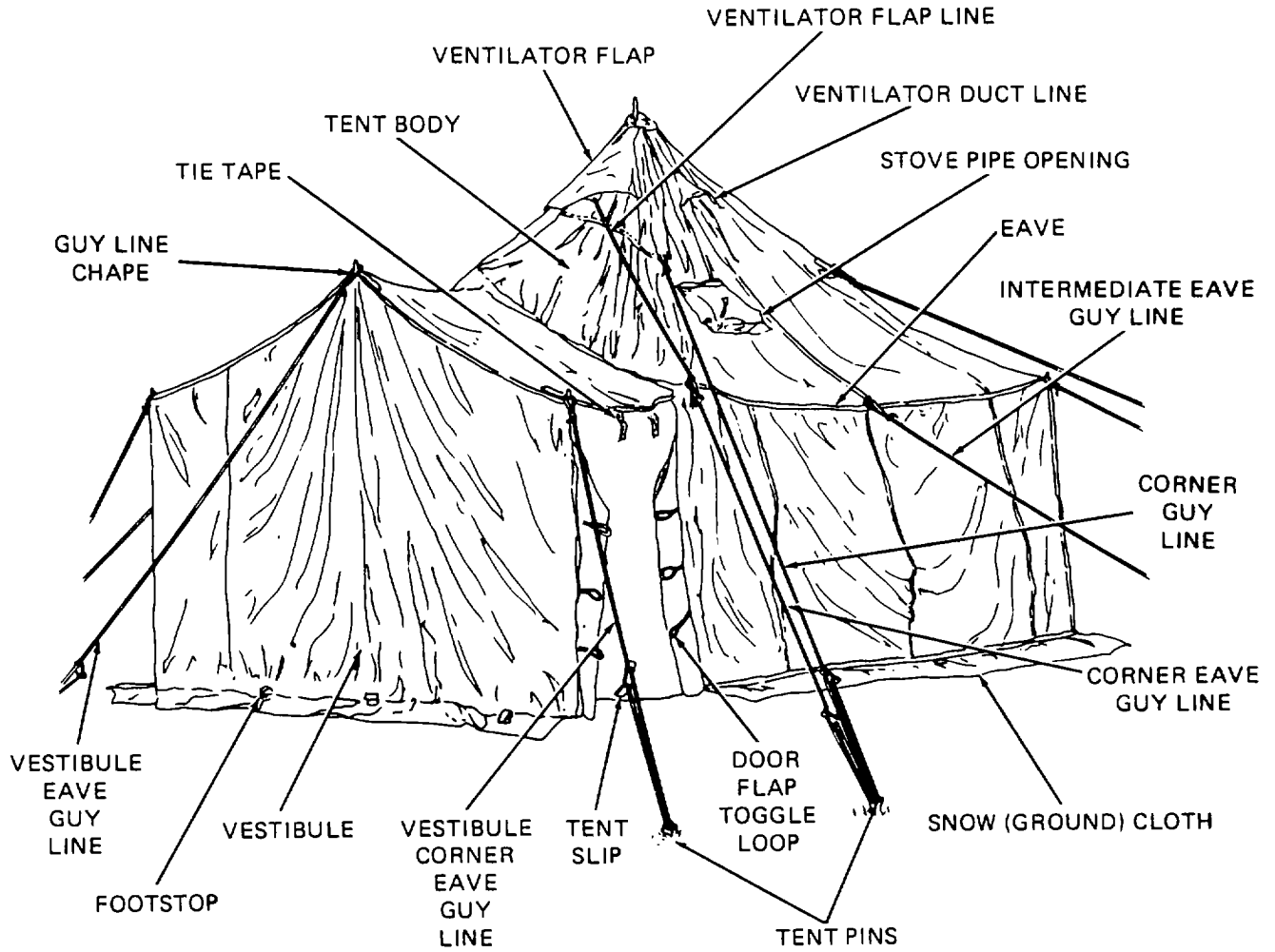

4890-002

Figure 1-2. Small General Purpose Tent.

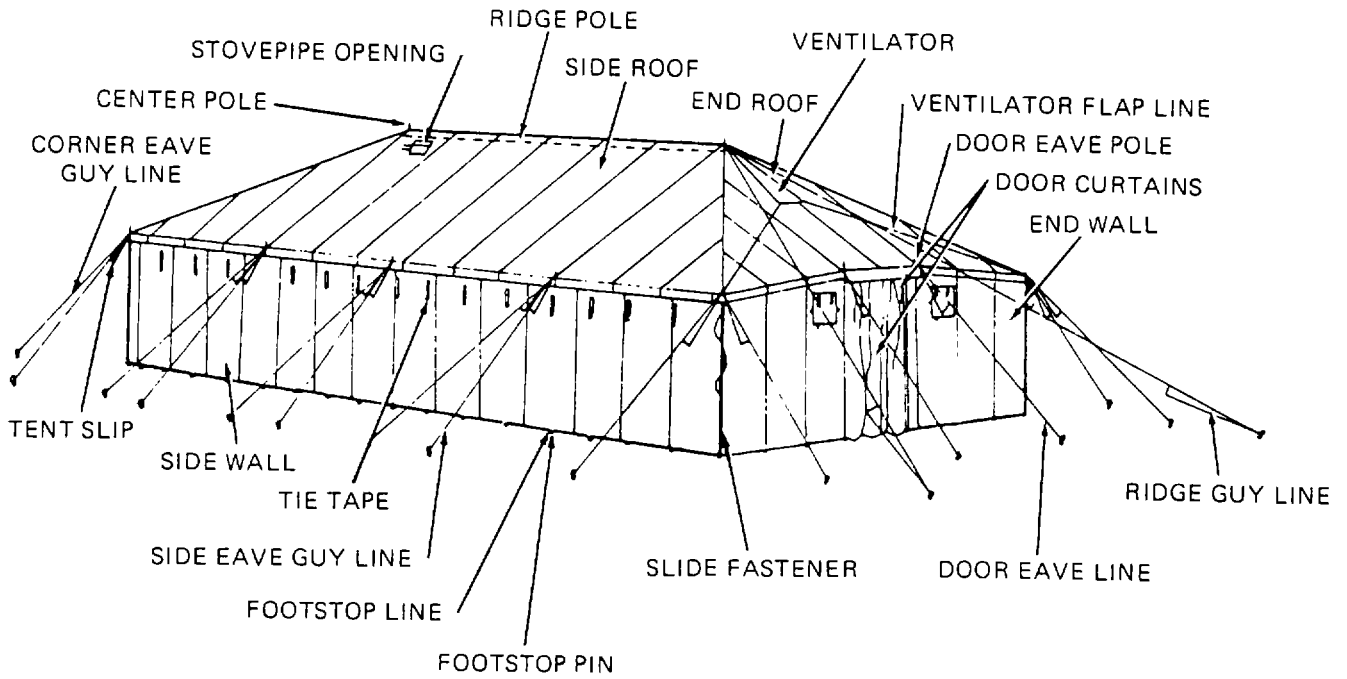

Figure 1-3. Medium General Purpose Tent, 3/4 Left View.

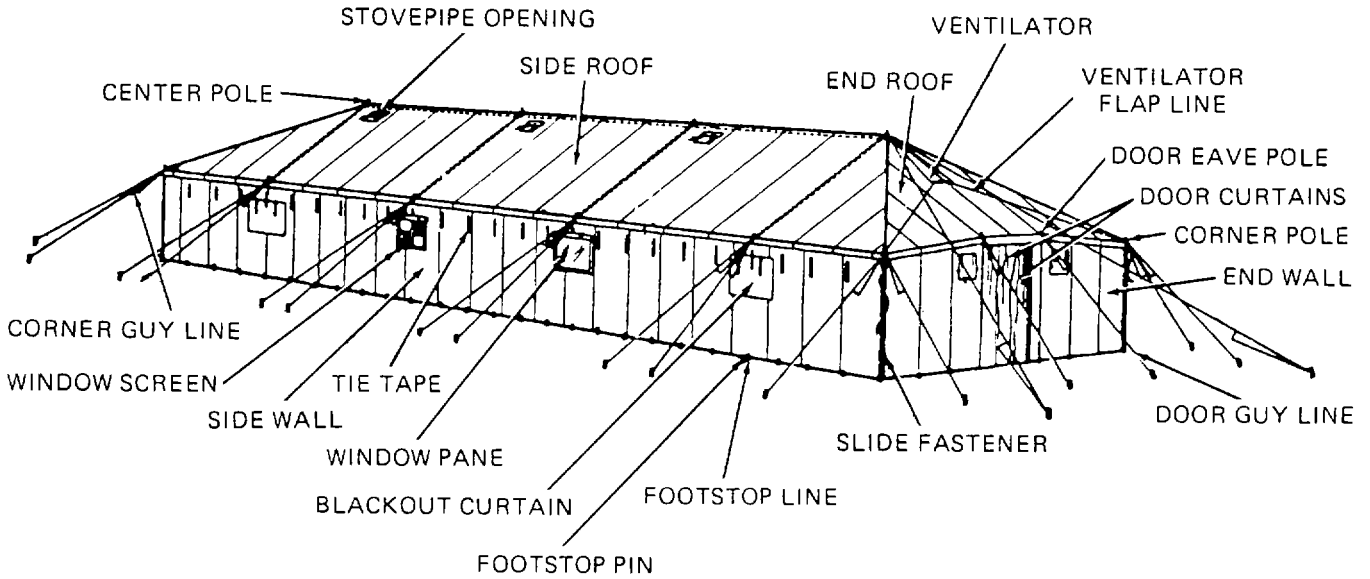

Figure 1-4. Large General Purpose Tent, 3/4 Left View.

1-8. Equipment Data.

a. Small General Purpose Tent.

(1) Dimensions.

Height of peak	10 ft. (feet) 6 in. (inches)
Height of eaves	5 ft.
Length of (each flat of hexagonal)	8 ft. 9 in.
Width (diameter of hexagonal)	17 ft. 6 in.
Floorspace	198.9 sq. ft. (square feet)

(2) Shipping weight and cube.

Tent	116 lb. (pounds)
Liner	23 lb.
Pins and poles	47 lb.
Cube, tent	8 cu. ft.
Cube, liner	2 cu. ft.

b. Medium General Purpose Tent.

(1) Dimensions.

Height of ridge	10 ft.
Height of eaves	5 ft. 6 in.
Length	32 ft. 8 in.
Width	16 ft.
Floorspace	512 sq. ft

(2) Shipping weight and cube.

Tent	334 lb.
Liner	100 lb.
Pins and poles	200 lb.
Cube, tent	33 cu. ft.
Cube, liner	14 cu. ft.

c. Large General Purpose Tent.

(1) Dimensions.

Height of offset ridge	12 ft. 3 in.
Height of eave	5 ft. 6 in.
Length	52 ft.
Width	18 ft.
Floorspace	936 sq. ft.

(2) Shipping weight and cube.

Tent	420 lb.
Liner	155 lb.
Pins and poles	245 lb.
Cube, tent	69 cu. ft.
Cube, liner	15 cu. ft.

d. Ground Plan.

- (1) Small general purpose tent (figure 4-2)
- (2) Medium general purpose tent (figure 4-4)
- (3) Large general purpose tent (figure 4-6)

1-9. Safety, Care, and Handling. Throughout this manual are warnings, cautions and notes designed to protect personnel and equipment when handling the tents. Learn the warnings on the warning page before attempting to perform maintenance on the tent, and observe all warnings, cautions and notes as you come upon them in the text.

Section III. PRINCIPLES OF OPERATION.

1-10. Principles of Operation.

a. Small General Purpose Tent. This tent is normally used as a command post, fire direction center, battalion aid station, or shelter for 10 individuals, their clothing and their equipment. Both front and rear doors are provided with a lacing flap arrangement that permits erection of two tents in tandem and the installation of a vestibule for additional warmth under extreme cold and windy conditions.

b. Medium General Purpose Tent. This tent is designed for use in artillery operations, housing components of a field bakery, or quarters for troops. It may also be used as a command post, fire control support center, mess hall, storage, or ward of a field hospital. A liner may be installed to retain heat in cold weather operations.

c. Large General Purpose Tent. The large tent is designed for use as a hospital ward, surgical operating room, command post, fire direction center or mess hall. It may also be used for storage, as an assembly tent, or quarters for troops. A liner may be installed to retain heat in cold weather operations.

CHAPTER 2
OPERATING INSTRUCTIONS

	Page
OVERVIEW	2-1
SECTION I. Description and Use of Operator's Controls	2-1
SECTION II. Operator PMCS	2-16
SECTION III. Operation Under Usual Conditions.....	2-20
SECTION IV. Operation Under Unusual Conditions	2-26

OVERVIEW

This chapter provides information for operation of the small, medium, and large general purpose tent.

Section I. DESCRIPTION AND USE OF OPERATOR'S CONTROLS

2-1. General.

- a. The instructions in this section are for the information and guidance of personnel responsible for operation of the general purpose tents, large, medium, or small.
- b. The operator must know how to perform every operation of which the tents are capable. This section contains information on those controls, or controllable tent components needed to operate the tent. These include doors, screen doors, ventilators, screen walls, stovepipe openings, and sidewalls.

2-2. Small General Purpose Tent Controls.

- a. Doors (Front or Rear). The tent has two doors seven feet high, on opposite sides, which may be equipped with screen doors that are provided. When tent liner is erected there are doors in liner sidewall matching tent doors. The doors are operable from inside or outside the tent (figures 2-1, 2-2 and 2-3).

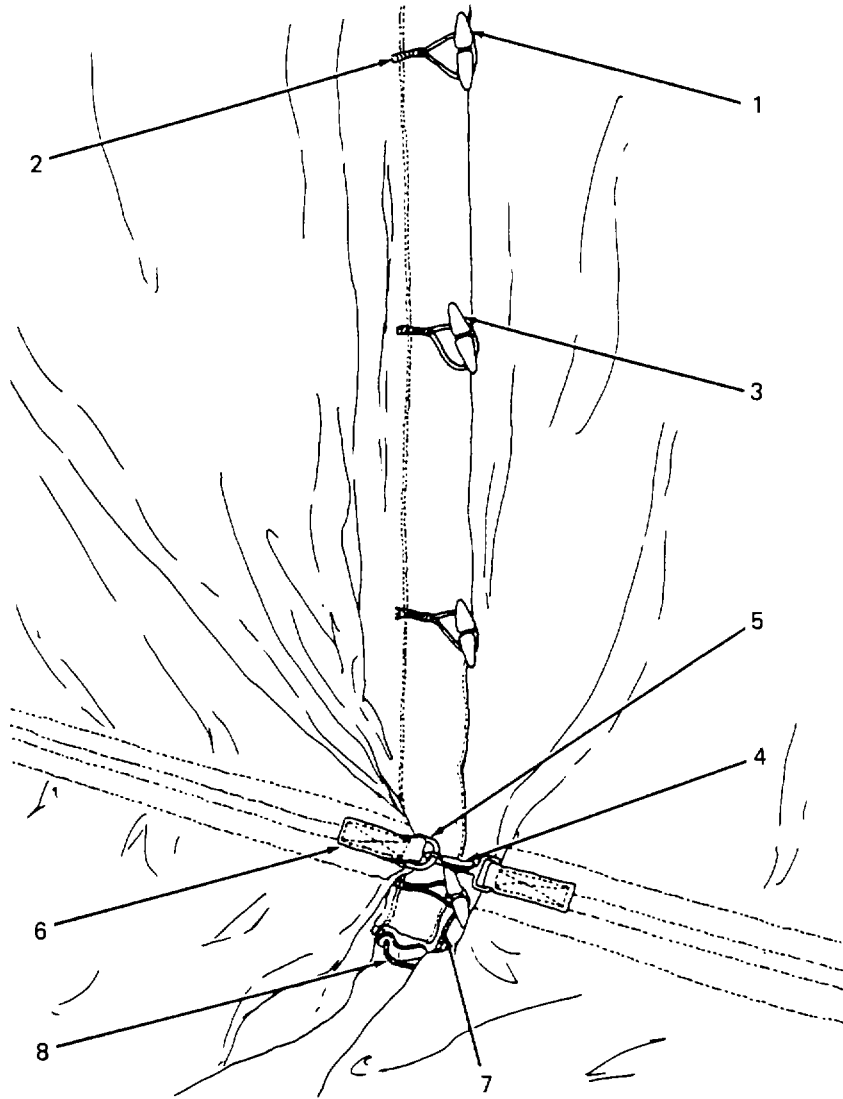

Figure 2-1. Small Tent Door Closed.

Key	Control	Function
1	Wood Toggle	Secures door closed.
2	Toggle Loop	Holds toggle to secure door.
3	Twine	Fastens toggle to tent.
4	Snaphook	Secures bottom of door closed.
5	D-Ring	Used to secure snaphook.
6	D-Ring Chape	Fastens D-ring to tent.
7	Footstop Line	Secures door bottom to ground.
8	Footstop Pin	Secures footstop line.

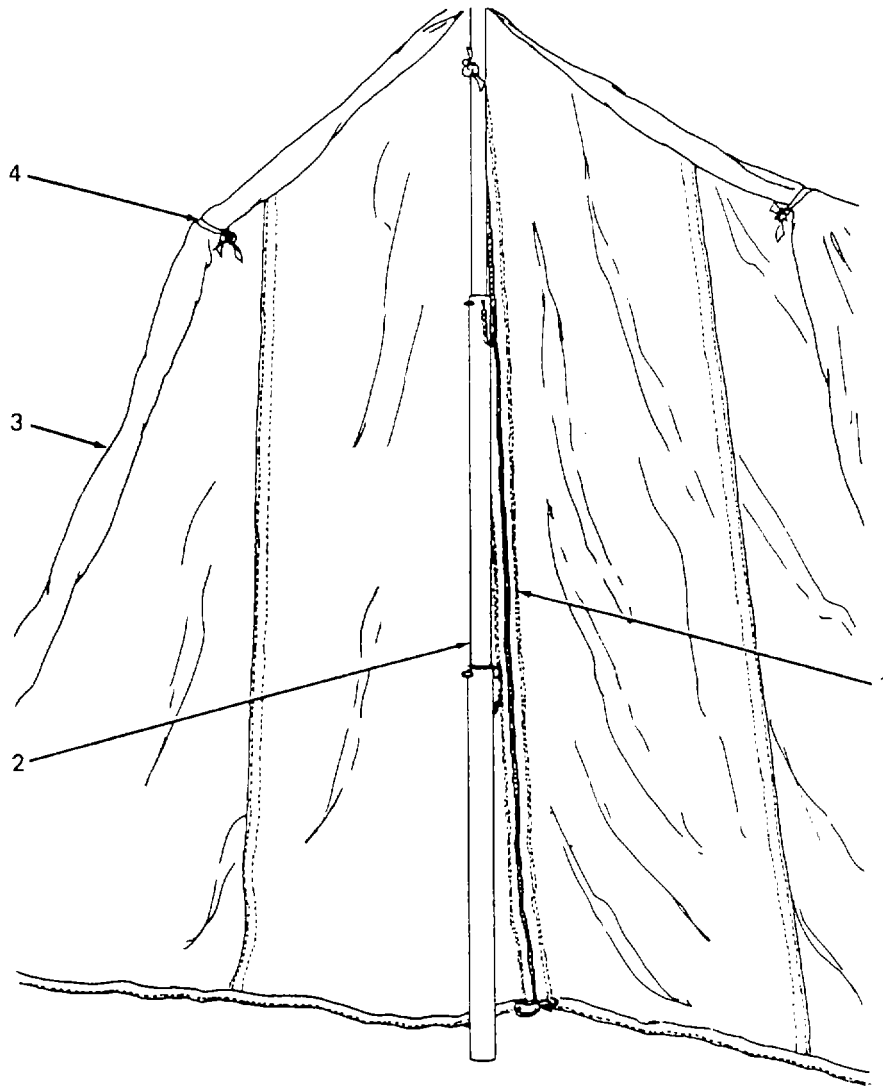

Figure 2-2. Tent Door Closed (Inside View).

Key	Control	Function
1	Slide Fastener	Seals door to retain heat inside tent and keep out moisture.
2	Adjustable Door Eave Tent Pole	Adjusts tent height to allow door to hang straight and close properly.
3	Liner (shown rolled back)	Additional insulation in cold weather.
4	Tie Tape	Used to secure rolled back liner.

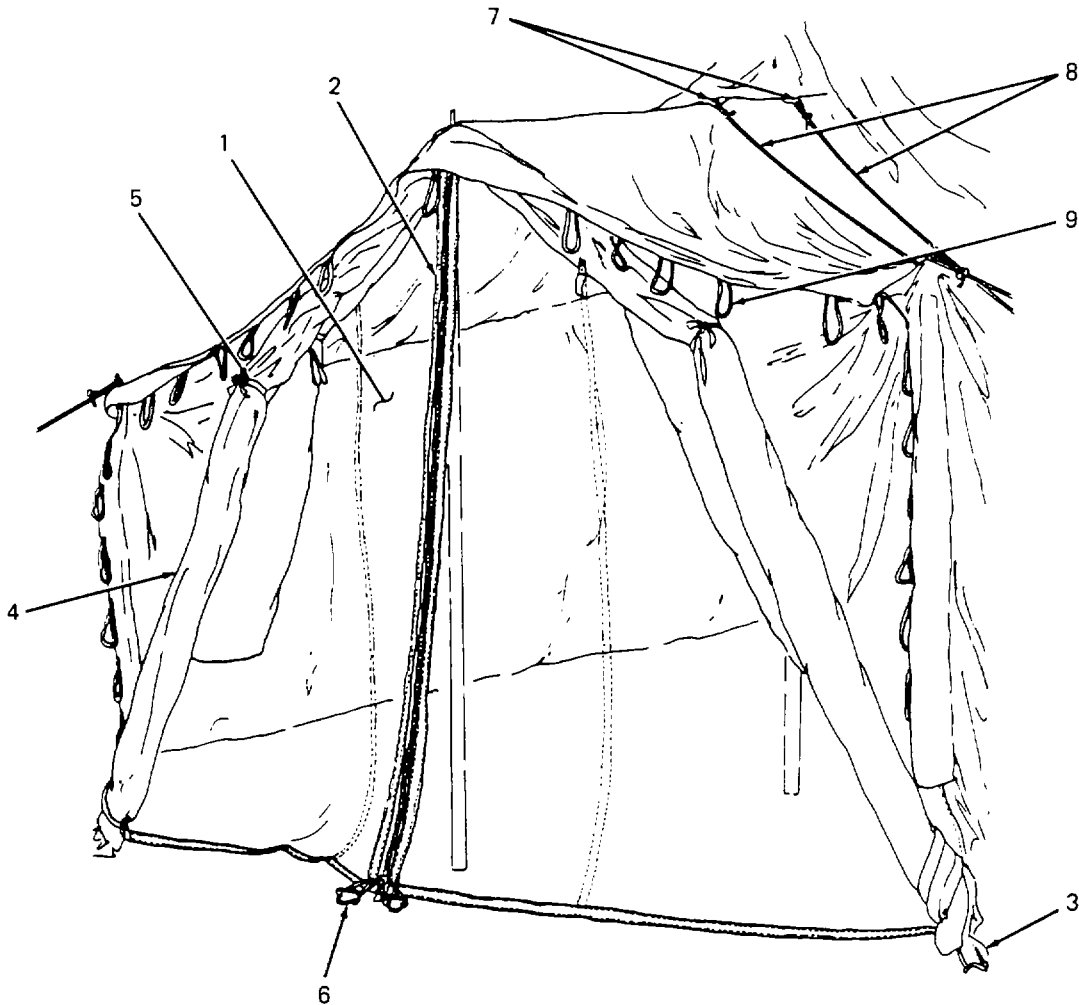
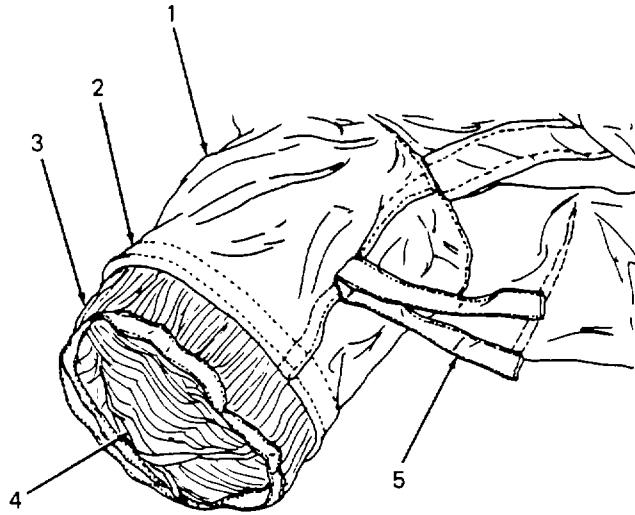

Figure 2-3. Tent and Liner Doors Open, With Flaps Rolled and Tied.

Key	Control	Function
1	Screen Door	Keeps out insects when tent door is open.
2	Slide Fastener	Keeps screen door closed.
3	Tent Pin	Secures tent bottom edge to ground.
4	Tent Flap (shown rolled back)	Closes tent.
5	Tie Tapes	Used to secure rolled back tent flaps.
6	Footstop Lines	Used to keep screen secure, straight and close to ground.
7	Ventilator Flap	Covers ventilator opening in cold weather.
8	Ventilator Flap Lines	Used to secure ventilator flap.
9	Becket	Loops inside tent to which tie tapes are secured.

b. Ventilators. This tent has six ventilators, four with inside ducts (view A, figure 2-4) and outside covers with stiffener (view B) to hold it open. Two screened and flapped openings (figure 2-5) provide balance of ventilation. The ventilating ducts have tie tapes for closing, when not required.



VIEW A. INSIDE TENT

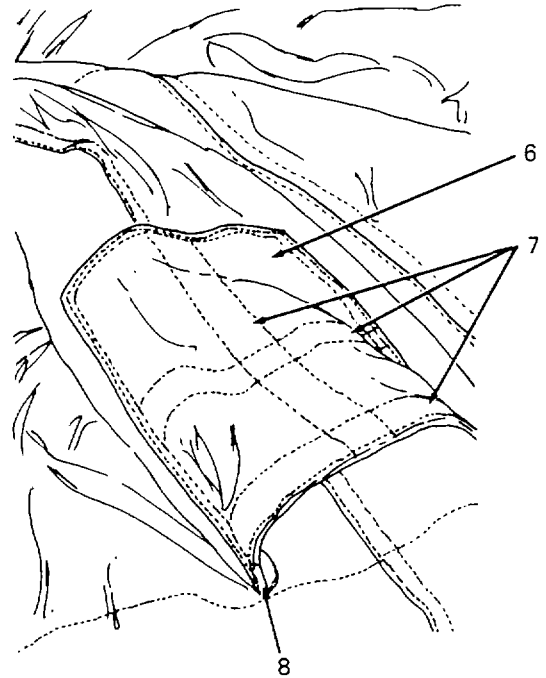

VIEW B. OUTSIDE TENT

Figure 2-4. Ventilator Duct, and Cover (Small Tent).

Key	Control	Function
1	Duct	Provides opening for ventilation of tent.
2	Stiffener	Keeps duct orifice open.
3	Sleeve Screen	Filters out dirt and insects blown in from outside.
4	Face Screen	Filters and retains dirt and insects blown in from outside.
5	Tie Tapes	Used to close off duct inside tent.
6	Cover	Keeps rain, snow and large debris out of duct.
7	Reinforcements	Keeps cover away from duct entrance.
8	Stiffener	Keeps cover open (away from tent).

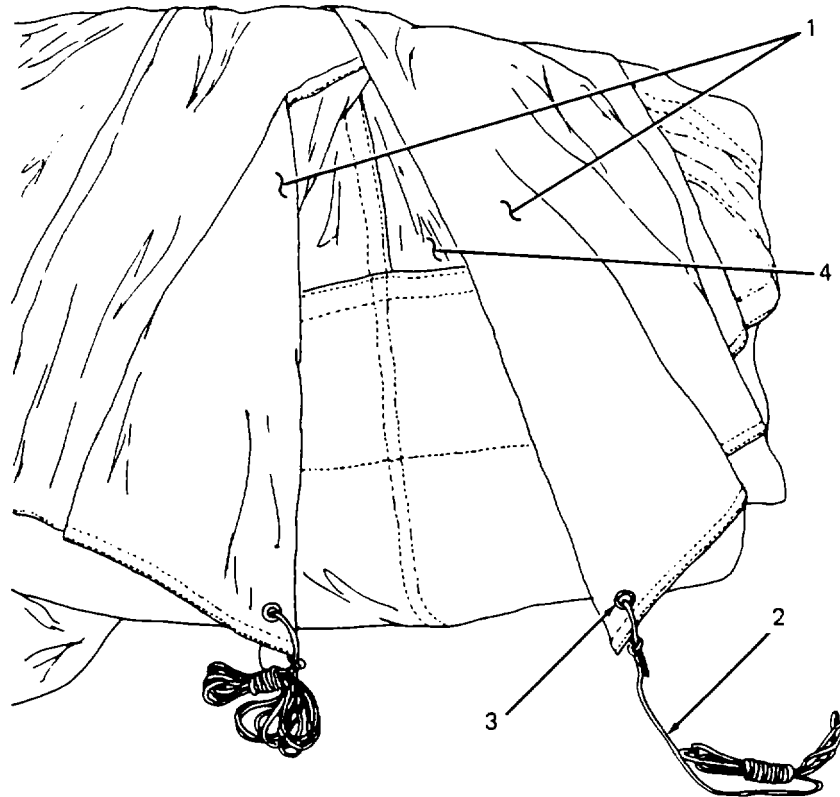

Figure 2-5. Roof Ventilator and Flaps, Outside View.

Key	Control	Function
1	Roof Ventilator Flaps	Cover screened opening in tent.
2	Ventilator Flap Line	Used to secure ventilator flap.
3	Grommet	Used for attachment of ventilator line to flap.
4	Screen	Filters out dirt and insects.

c. Stovepipe Opening. A stovepipe opening is provided so that the stack of a heating stove may be vented through the top of the tent when needed in cold weather (figure 2-6). A drip cap prevents seepage of moisture into the opening on the side facing up. A stovepipe shield insulates the hot stack from the tent fabric and an opening in the shield fits snugly to keep out rain or snow (figure 2-7).

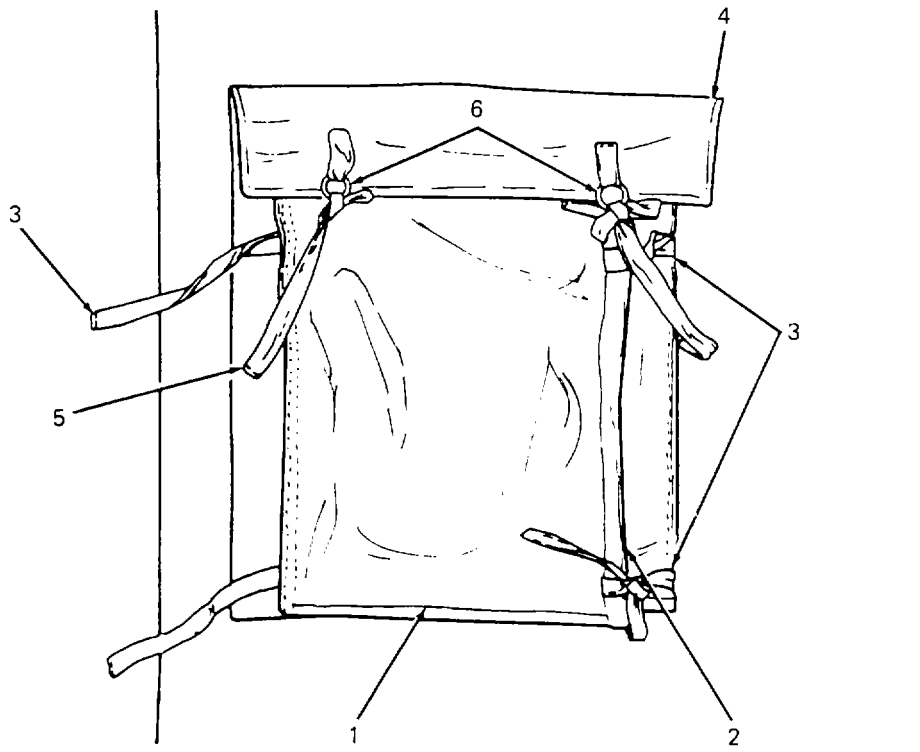

Figure 2-6. Stovepipe Opening Closed (Outside View).

Key	Control	Function
1	Left Flap (shown closed)	Covers stovepipe opening.
2	Right Flap (shown rolled up)	Covers stovepipe opening and lays over left flap.
3	Left and Right Flap Tie Tapes (left flap closed, ties loose)	Secure flaps when rolled up.
4	Drip Cap	Keeps moisture out of stovepipe opening.
5	Drip Cap Ties	Secure drip cap when closed.
6	Round Rings	Secure drip cap ties to drip cap.

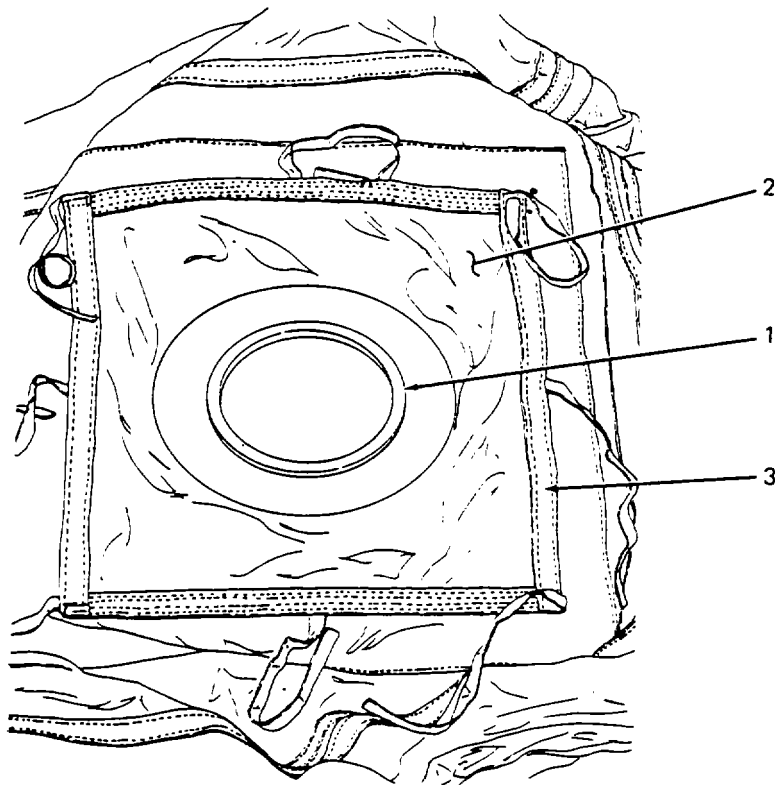

Figure 2-7. Stovepipe Opening - Small Tent (Inside View).

Key	Control	Function
1	Stovepipe Opening	Opening in tent for stoves smoke venting.
2	Stovepipe Shield	Insulates tent from heat and keeps out moisture.
3	Binding	Secures shield to tent.

2-3. **Medium General Purpose Tent Controls.**

a. Doors (Front or Rear). There is a double door at each end of the tent. An outside curtain slides to the left to uncover the tent opening and an inside curtain slides to the right to uncover the tent opening (figure 2-8). There is a double screen door at each end of the tent consisting of a left and right screen door that overlaps to keep out insects (figure 2-9).

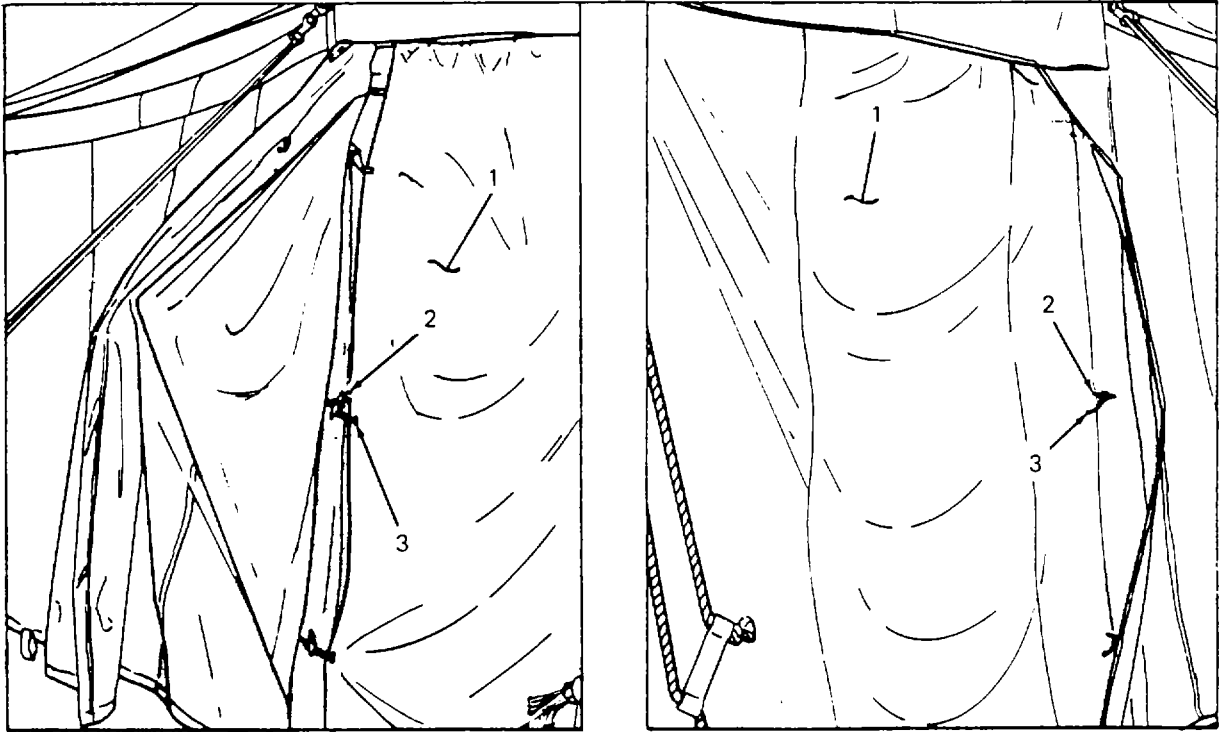
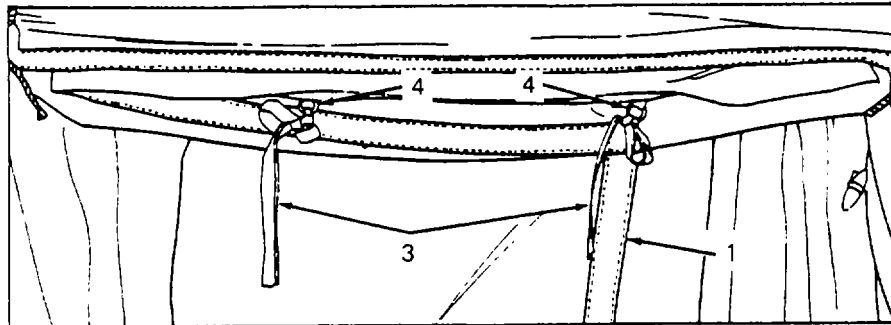
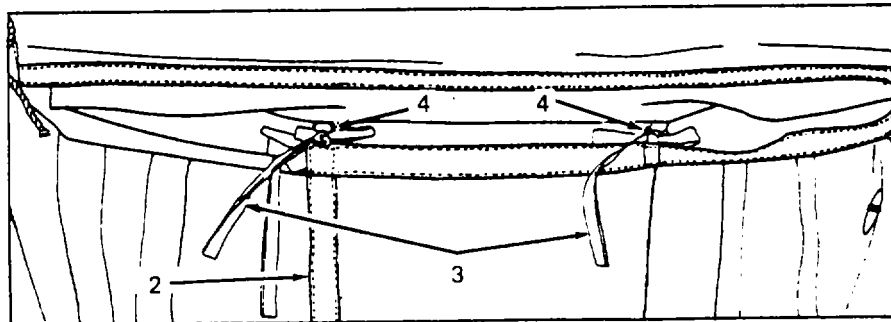

Figure 2-8. Double Door Entrance (Medium and Large Tents).

Key	Control	Function
1	Curtain (inside and outside)	Covers entrance.
2	Wood Toggle	Secures inside or outside curtain.
3	Toggle Lamp	Fastens wood toggle to curtain.



VIEW A. LEFT SCREEN DOOR



VIEW B. RIGHT SCREEN DOOR

Figure 2-9. Left and Right Screen Doors (Medium and Large Tents).

Key	Control	Function
1	Left Screen Door	Keeps out dirt and insects.
2	Right Screen Door	Keeps out dirt and insects.
3	Tie Tapes	Secure screens when closed.
4	Round Rings	Secure tie tapes to tent.

b. Ventilators. Two ventilators, one at each end of tent, are screened openings covered with flaps that may be tied back similar to small tent (figure 2-5).

c. Sidewalls. The sidewalls are normally down, and footsteps pinned to ground (figure 1-3). (Also liner and screen sidewalls, when liner is erected). Sidewalls (also liner and screen sidewalls) may be rolled up in warm weather.

d. Stovepipe Openings. The medium tent is provided with two stovepipe openings. When closed, they are similar to the opening in the small tent (figure 2-6). Open, the stovepipe shield is larger (figure 2-10).

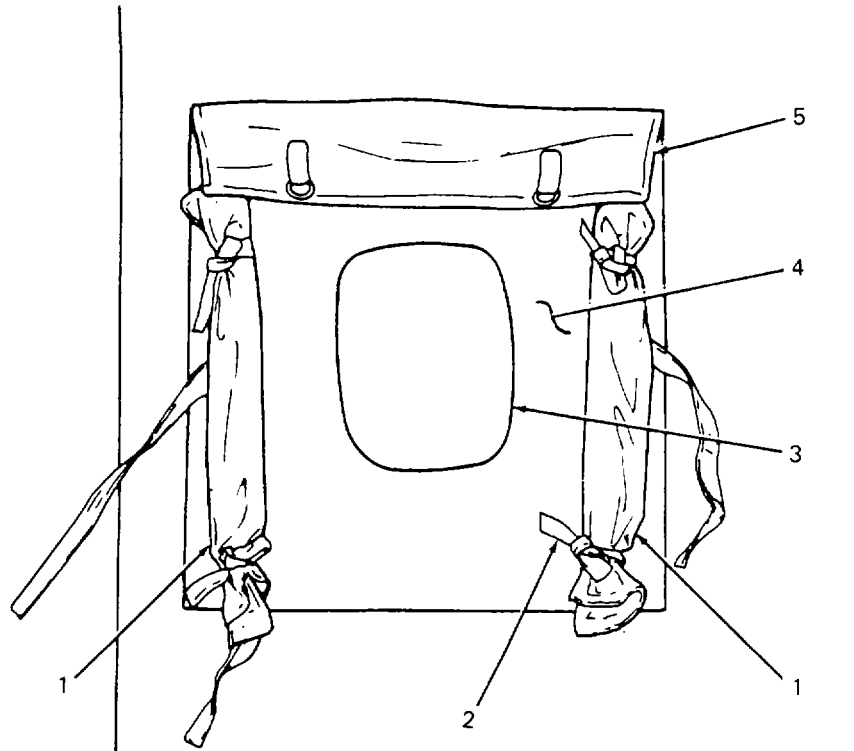

Figure 2-10. Stovepipe Opening Open (Medium and Large Tents).

Key	Control	Function
1	Flaps (shown rolled up)	Cover stovepipe opening.
2	Tie Tapes	Secure flaps when rolled up.
3	Stovepipe Opening	Opening in tent for stove smoke venting.
4	Stovepipe Shield	Insulates tent from heat and keeps out moisture.
5	Drip Cap	Keeps moisture out of stovepipe opening.

2-4. **Large General Purpose Tent Controls.**

a. Doors (Front and Rear). The operation of doors (figure 2-8) and door screens (figure 2-9) for the large tent is the same as that described for the medium tent (paragraph 2-3).

b. Ventilators. Two ventilators, one at each end of the tent, are screened openings covered with flaps that may be tied back similar to the small tent (figure 2-5).

c. Sidewalls. The sidewalls are normally down, and footstops pinned to the ground (figure 1-4). (Also, liner and screen sidewalls, when liner is erected.) Sidewalls (also liner and screen sidewalls) may be rolled up in warm weather.

e. Windows. The large tent has eight windows (four on each side) that are screened openings a plastic window pane, (slide fastener on three sides), tie tapes, and a blackout flap (figure 2-11).

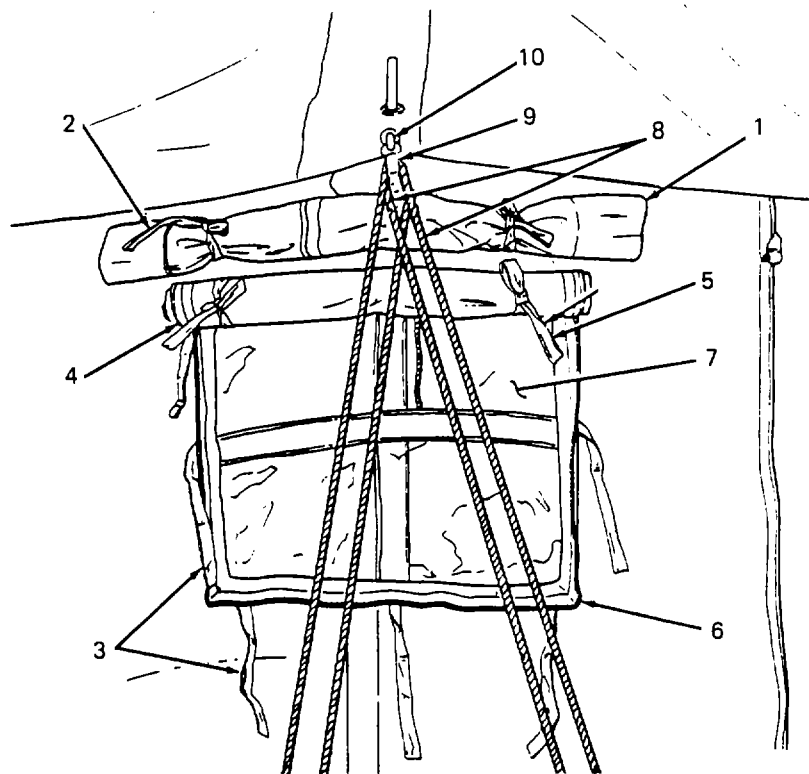

Figure 2-11. Windows (Large Tent).

Key	Control	Function
1	Blackout Flap (shown rolled up)	Covers window under blackout conditions.
2	Blackout Tie Tapes (2 tapes)	Secure blackout flap when rolled up.
3	Blackout Tie Tapes (5 tapes)	Secure blackout flap when covering window.
4	Plastic Window Pane (shown rolled up - open)	Allows light to enter tent.
5	Window Pane Ties	Secure window pane when open (rolled up).
6	Window Panel Slide Fastener down).	Secures window pane when closed (rolled down).
7	Screen	Keeps out insects and flying debris.
8	Dual Eave Guy Lines window opening in tent body.	Anchor tent at weak point in tent covered by window opening in tent body.
9	Fairlead	Supports guy lines which are threaded through it.
10	Hook	Attaches fairlead to tent.

Section II. OPERATOR PREVENTIVE MAINTENANCE CHECKS AND SERVICES (PMCS)

2-5. **General.** In order to be sure the tent is always ready for use, it must be inspected at specific intervals so that defects may be found and corrected before they result in serious damage or failure.

- a. Before You Operate. Always keep in mind the CAUTIONS and WARNINGS. Perform your before (B) PMCS.
- b. While You Operate. Always keep in mind the CAUTIONS and WARNINGS. Perform your during (D) PMCS.
- c. After You Operate. Be sure to perform your after (A) PMCS.
- d. Weekly. Perform your weekly (W) PMCS.
- e. Once Each Month. Perform your monthly (M) PMCS.
- f. If Your Equipment Fails to Operate. If your equipment does not perform as required, notify higher level of maintenance. Report any malfunctions or failures on the proper DA Form 2404 or refer to DA Pam 738-750.

2-6. Purpose of PMCS Table. Your Preventive Maintenance Checks and Services table lists the inspections required to keep your equipment in good operating condition.

2-7. Explanation of Columns.

- a. Item Number. The item number is to be used as a source number for the TM number column on DA Form 2404, Equipment Inspection and Maintenance Worksheet, when recording PMCS results.
- b. Item To Be Inspected. This column lists the components that require inspection.
- c. Procedures. This column lists the faults to check for and procedures to follow.
- d. Equipment Is Not Ready/Available If. This column tells you when and why your equipment cannot be used.

NOTE

Inspect tent anchoring support, and tightness of support lines daily.

Table 2-1. Operator Preventive Maintenance Checks and Services.

NOTE

Within designated interval, these checks are to be performed in the order listed.

B - Before D - During A - After W - Weekly M - Monthly

Item no.	Interval					Item to be Inspected	Procedures Check for and have repaired or adjusted as necessary	Item is Not Ready/ Available If:
	B	D	A	W	M			
1						Tent	a. Check that tent is clean and free of mildew. b. Check that all anchoring and support components, tie tapes and hardware are present. c. Inspect wooden toggles for cracks, or loose fasteners.	Anchoring and support components, tie tapes and hardware are missing. Toggles are damaged or loose.

Table 2-1. Operator Preventive Maintenance Checks and Services (cont).

B - Before

D - During

A - After

W - Weekly

M - Monthly

Item no.	Interval					Item to be Inspected	Procedures Check for and have repaired or adjusted as necessary	Item is Not Ready/ Available If:
	B	D	A	W	M			
2						Anchoring Components	a. Check that pins are in place at all required positions per ground plan, and that all lines are properly connected and adjusted at the slips.	
3						Support Components	a. Inspect wood poles for cracks, or breaks. b. Inspect metal poles for bends or missing hardware. c. Replace defective poles.	Pins are damaged. Poles are damaged or have hardware missing
4						Tent Fabric	a. Inspect fabric for rips, tears, holes, cuts, broken or missing stitching, mildew, signs of extreme wear, or any other defect. b. Report all defects to unit maintenance personnel.	Tent fabric is torn or damaged.
5						Webbing or Seams	a. Inspect all webbing and seams for broken or loose stitching. b. Mark and report all defects noted.	Webbing and seams are loose.
6						Tie Tapes	a. Check that all tie tapes are present, in serviceable condition. b. Check that all the tapes are being used properly.	Tie tapes are missing or unserviceable.

Table 2-1. Operator Preventive Maintenance Checks and Services (cont).

B - Before

D - During

A - After

W - Weekly

M - Monthly

Item no.	Interval					Item to be Inspected	Procedures Check for and have repaired or adjusted as necessary	Item is Not Ready/ Available If:
	B	D	A	W	M			
7						Slide Fasteners	<p>a. Check that all slide fasteners at corners, doors and windows are securely sewed to fabric, that there are no missing loops or stops.</p> <p>b. Lubricate a sticking slide or one that moves with difficulty.</p> <p>c. Report a defective slide to unit maintenance.</p>	Slide fasteners are missing or not secure.
8						Hardware	<p>a. Check that all D-rings, grommets, round rings, peak plate, ridge plates, tent slips, fairleads, eyes, hooks are present, in serviceable condition.</p> <p>b. Check that all hardware is in proper use.</p>	Hardware is missing or unserviceable.
9						Windows	<p>a. Inspect windows (on large tents) for torn screen, defective window pane, inoperable slide fasteners, missing tie tapes or torn or missing stitching.</p> <p>b. Lubricate a sticking slide.</p> <p>c. Mark and report other defects to unit maintenance.</p>	Windows are defective or screens are torn.
10						Liner and Vestibule	Repeat checks 1 through 7 for liner or vestibule when in use.	Defective vestibule or liner.

Section III. OPERATING UNDER USUAL CONDITIONS

2-8. General.

- a. The instructions in this section are for the information and guidance of personnel responsible for operation of the general purpose tents, large, medium, or small.
- b. The operator must know how to perform every operation of which the tents are capable. This section contains information on opening and closing of doors, screen doors, ventilators, screen walls, stovepipe openings, on use of snow cloths and coordinating several motions to perform specific tasks for which the equipment was designed. Since nearly every use presents a different problem, the operator may have to vary given procedures to obtain maximum benefits under existing climatic conditions.

2-9. Operation of Small General Purpose Tent.

- a. Door (Front or Rear). The doors are operable from inside or outside the tent.
 - (1) Opening the door from outside.
 - (a) *Door* (figure 2-12). Remove toggles (1) from loops (2), snaphook (3) from D-ring (4), open slide fastener (5), then remove footstop lines (6) from tent pins. When liner and screen doors are not installed, lift either flap and enter tent. When liner and screen door installed, perform (b) below.
 - (b) *Screen* (figure 2-13). Open slide fasteners (1) in screen (2) and liner doors if installed, remove footstops (3) from pins, then enter tent. In mild weather, roll door (4) and liner flaps, and tie them back (5).

NOTE

Rolling of tent and liner flaps are not recommended, except in mild weather. Better insulation from heat or cold is provided when flaps are down and footstops are secured to pins.

- (2) *Opening the door from inside*.
 - (a) *Screen* (figure 2-13). Open slide fasteners (1) in screen (2) and liner doors if installed, remove footsteps (3) from pins, then enter tent. In mild weather, roll door and liner flaps, and tie them back (5).
 - (b) *Door* (figure 2-12) . Remove toggles (1) from loops (2), snaphook (3) from D-ring (4) and open slide fastener (5), then remove footstop line (6) from tent pins. When liner and screen doors are not installed, lift either flap for exit.

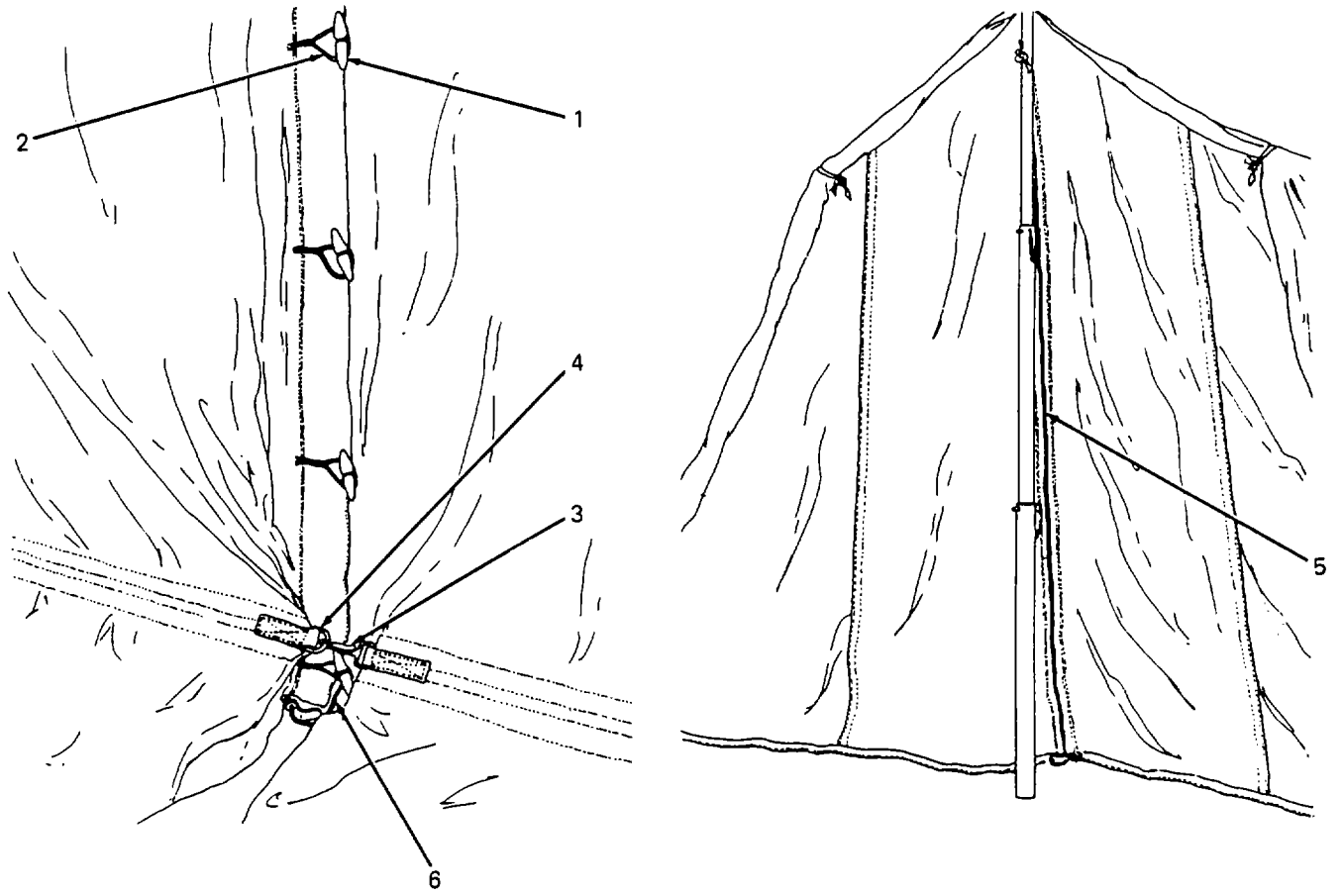

Figure 2-12. Opening Tent Door (Small Tent).

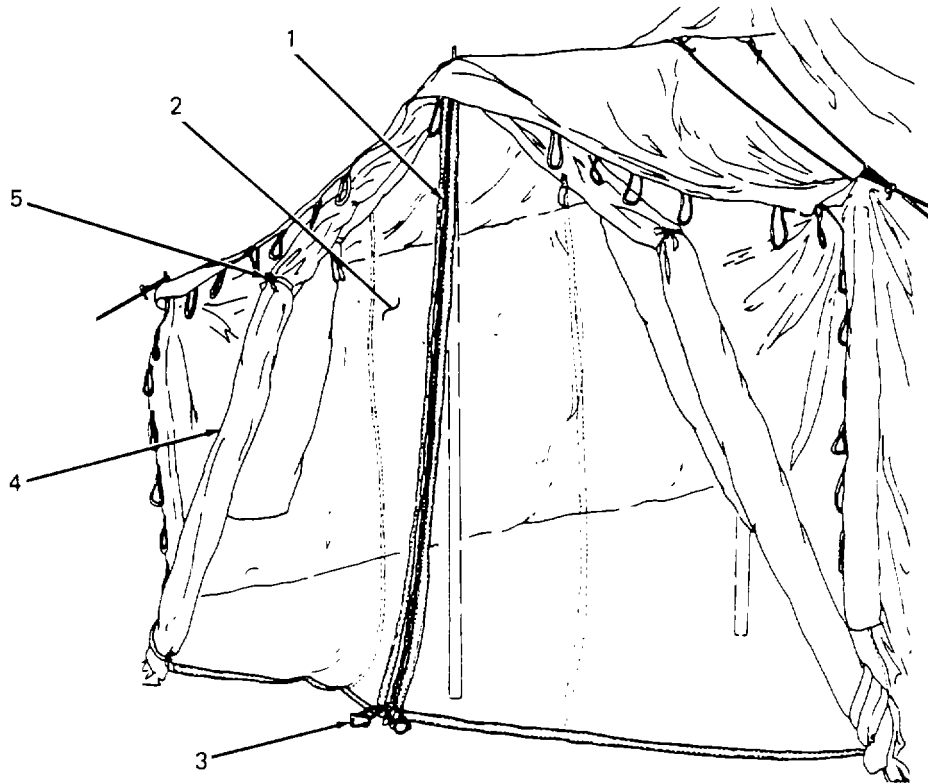

Figure 2-13. Opening Screen (Small Tent).

- b. Ventilators. This tent has six ventilators, four with inside ducts and two screened and flapped openings. Open as many as required for comfort.
- (1) Ventilator ducts (figure 2-14). To open any ventilating duct (1), untie tie tapes (2) as required.
 - (2) Ventilator flaps (figure 2-15). For additional ventilation, remove ventilator flap lines (1) from corner poles, then tie each flap line to opposite corner pole, holding flaps (2) open, leaving screen (3) uncovered.
- c. Snow (Ground) Cloths. For operation of snow cloths, see operation in extreme cold (para. 2-12).
- d. Stovepipe Opening. For operation of stovepipe opening, see operation in extreme cold (para. 2-12).

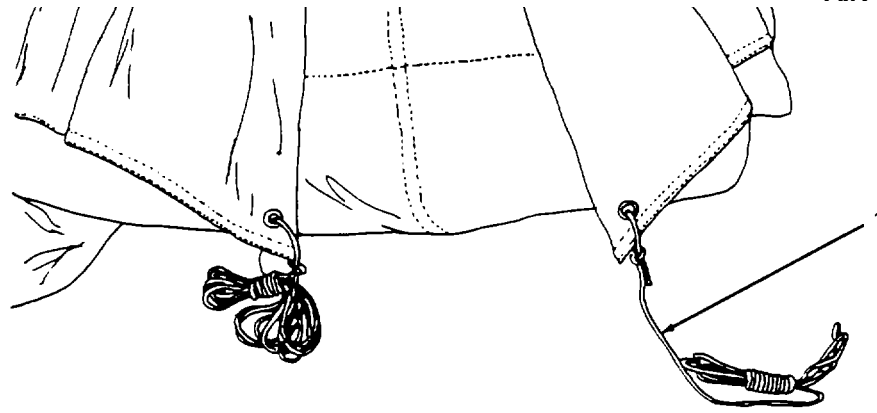

Figure 2-14. Opening Ventilating Duct (Small Tent).

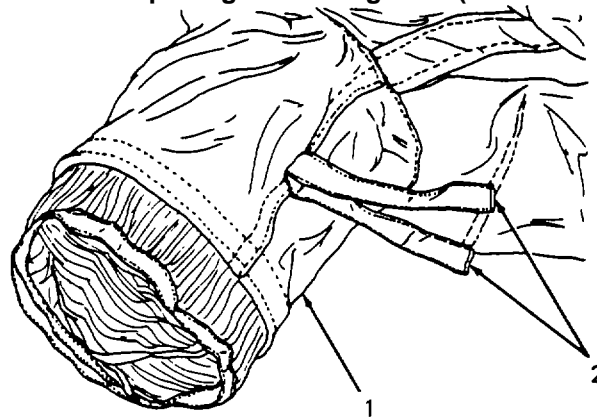

Figure 2-14. Opening Ventilating Duct (Small Tent).

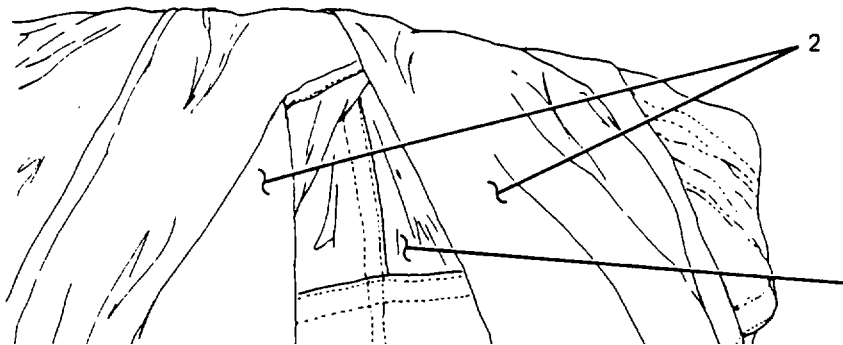
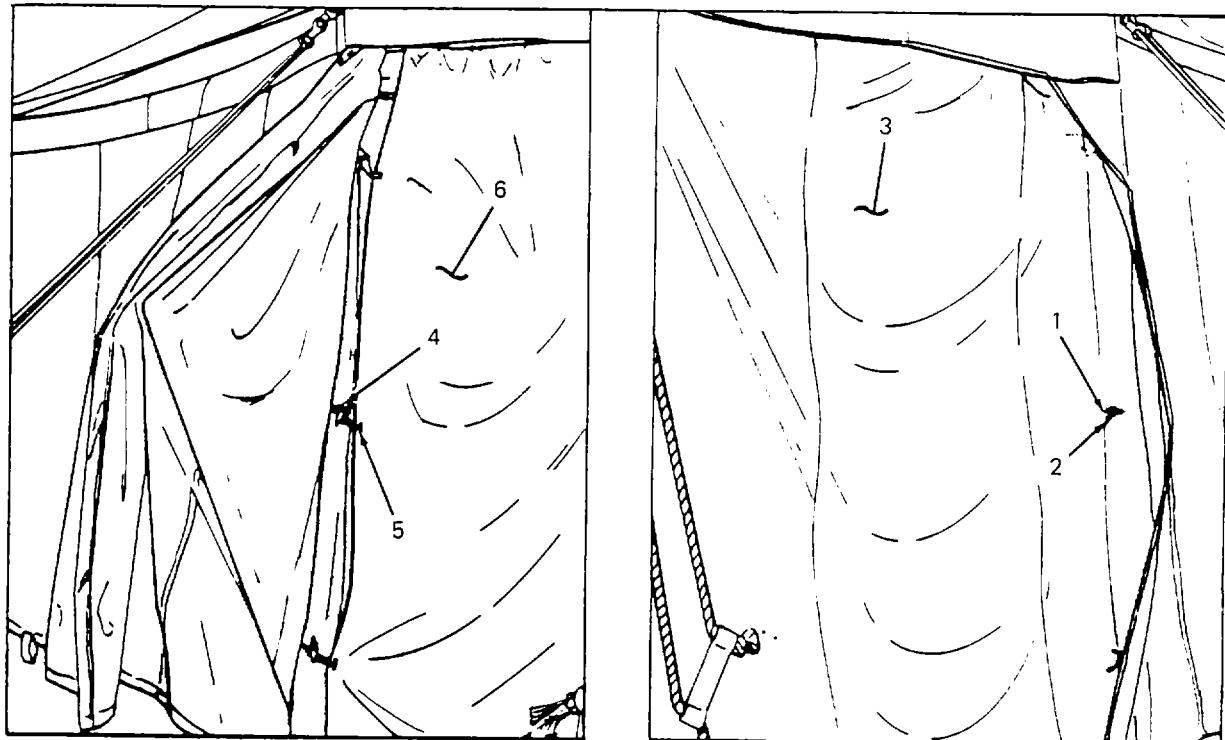

Figure 2-15. Opening Ventilator Flap.

2-10. Operation of Medium General Purpose Tent.

a. Opening Door (Front or Rear). There is a double door at each end of tent. To open either door, use the following instructions.

- (1) *Doors* (figure 2-16). Remove wood toggles (1) from toggle loops (2) on outside curtain (3) (view B) and slide curtain to left (view A). Remove wood toggles (4) from toggle loops (5) (view A) then slide inside curtain (6) to right.



VIEW A. INSIDE CURTAIN

VIEW B. OUTSIDE CURTAIN

4890-020

Figure 2-16. Opening Doors (Medium and Large Tents).

(2) *Screens* (figure 2-17). Untie tapes (1) from round rings (2) (view B), slide right door screen (3) to right, then secure tie tapes to door frame. Remove tie tapes (1) from round rings (2) (view A), slide left screen (3) to left, then secure the tapes to door frame.

(3) Open remaining door in a similar manner.

b. *Ventilators*. Two ventilators, one at each end of tent, are screened openings covered with flaps that may be tied back. Ventilators are the same as for the small tent. To open either ventilator, refer to paragraph 2-9.

NOTE

Ventilators in liners are screened openings without flaps.

c. *Sidewalls*. The sidewalls are normally down, and footsteps pinned to the ground. (Also liner and screen sidewalls, when liner is erected). To roll sidewalls of tent, proceed as follows:

(1) Untie comer lug tie tapes.

(2) Remove sidewall footsteps from pins.

(3) Use enough manpower to roll entire sidewall at one time, and from outside the tent, roll as tight as possible toward top, then secure sidewall to eaves with tie tapes.

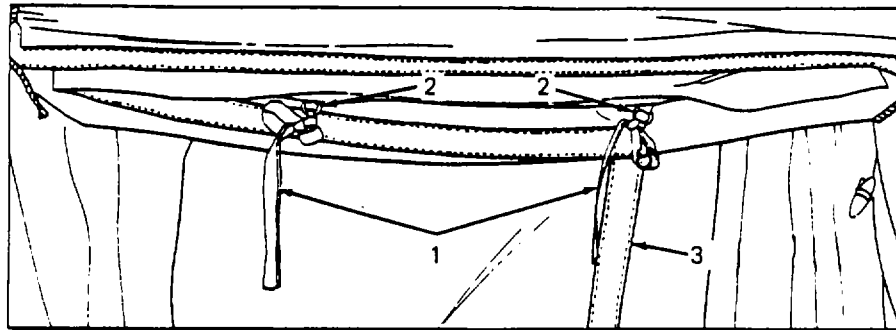

VIEW A. LEFT SCREEN DOOR

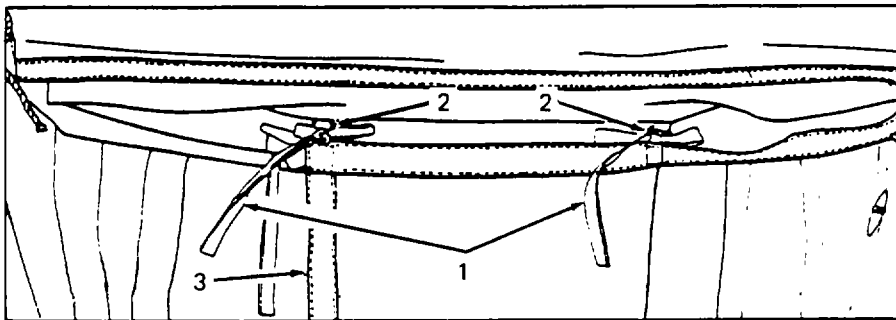

VIEW B. RIGHT SCREEN DOOR

Figure 2-17. Opening Screens (Medium and Large Tents).

NOTE

When liner is installed, roll liner sidewalls from inside tent in a similar manner.

(4) The sidewalls are normally down and footstops pinned to the ground.

d. Stovepipe Openings. Operate stovepipe openings as described in paragraph 2-12.

2-11. Operation of Large General Purpose Tent.

a. Opening Doors, Ventilators and Sidewalls. The operation of doors, ventilators, and sidewalls of the large tent is identical to that described for the medium tent in paragraph 2-10. Operate windows as described in b, below.

b. Opening Windows (figure 2-18). The large tent has eight windows (four on each side) that are screened openings in sidewall, with a plastic window pane, (slide fastener on three sides), tie tapes, and a blackout flap. Open as follows:

(1) Roll blackout flap (1) and secure with tie tapes (2).

(2) Open slide fastener (3), roll window pane (4), then secure with tie tapes (5).

c. Stovepipe Openings. Operate stovepipe openings in manner described in paragraph 2-12.

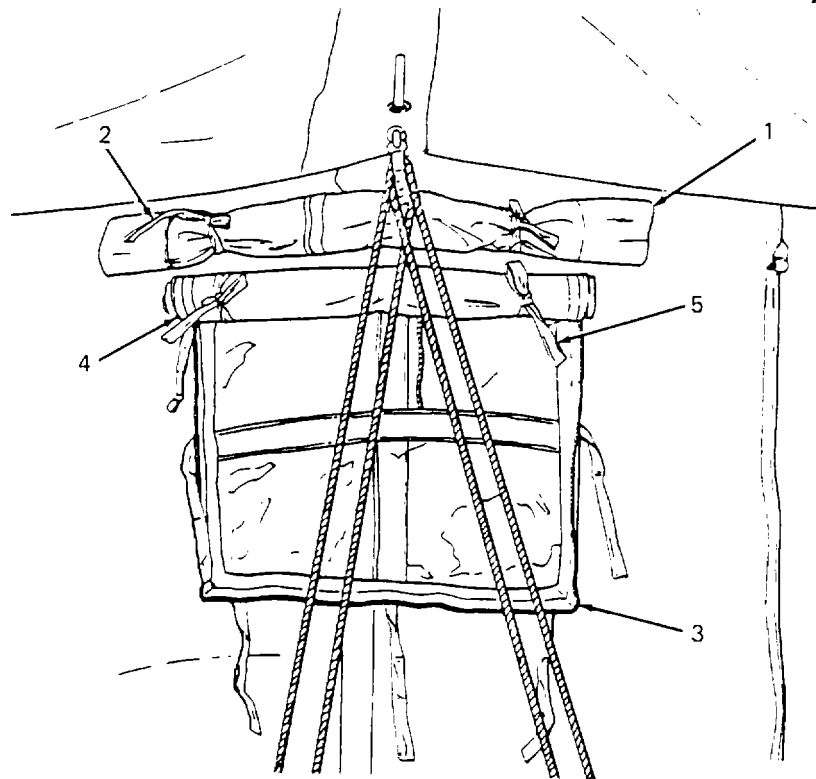

Figure 2-18. Opening Windows (Large Tent).

Section IV. OPERATION UNDER UNUSUAL CONDITIONS

2-12. Operation in Extreme Cold.

a. *Small General Purpose Tent.*

- (1) Erect liner (para. 4-12).
- (2) Erect vestibule (para. 4-12).
- (3) Operate stovepipe opening by referring to figure 2-19 and the following instructions:
 - (a) Untie drip cap tie tapes (1).
 - (b) Roll right flap (2) to right and secure with tie tapes (3).
 - (c) Roll left flap (4) to left and secure with tie tapes (5).

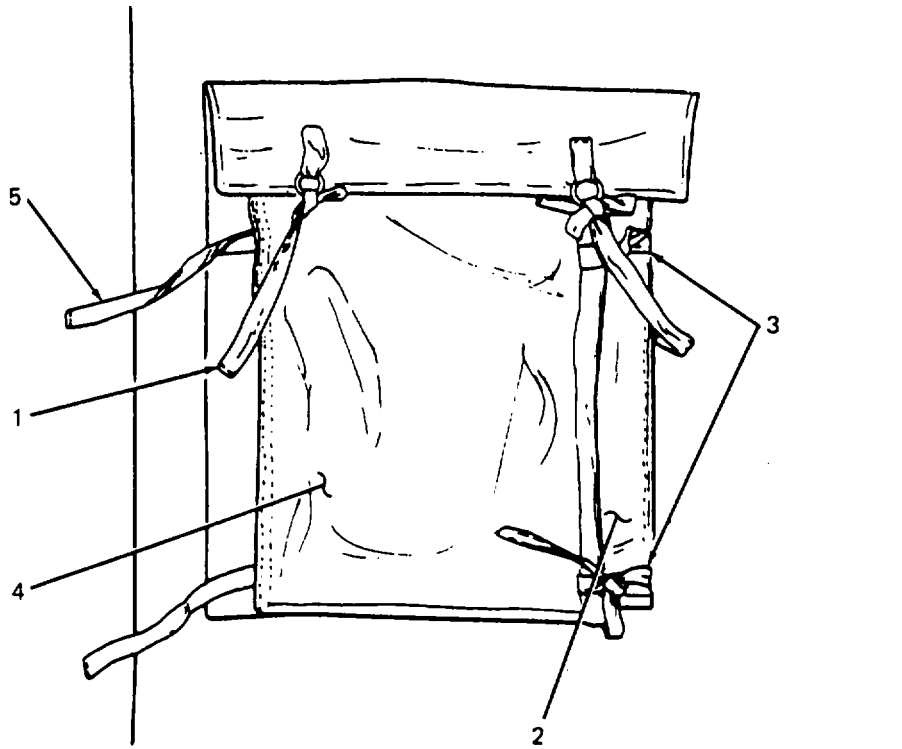

Figure 2-19. Opening Stovepipe Flaps.

- (4) Install stove (TM 10-4500-200-13).
- (5) Cover snow cloths on outside of tent and vestibule with rocks or limbs to prevent drafts from entering tent.
- (6) Keep all doors closed except when entering or exiting the tent.

NOTE

Check guy lines often during extreme weather. Be sure guy lines are taut and the tent wrinkle free. Loosen guy lines when moisture causes the tent to shrink.

b. Medium General Purpose Tent.

- (1) Erect liner (para. 4-12).
- (2) Operate stovepipe opening. Refer to paragraph a. (3) above.

CAUTION

Do not use liner when stovepipe opening is less than 16 inches square (figure 2-10).

- (3) Assure that Modification Work Order 10-8340-211-30/1 enlarging aperture in liner to 16 inch square has been complied with, and tie tapes of liner are secured to tent aperture tie tapes before installing stoves..

- (4) Install two stoves (TM 10-4500-200-13).

NOTE

Step (5) below is optional. The user may elect to use equipment, cots, etc., to hold flaps down.

- (5) Place two or three inches of dirt on ground flap inside tent and liner walls to prevent drafts from entering tent.
- (6) Keep all doors closed except when entering or exiting the tent.

NOTE

Check guy lines often during extreme weather. Be sure guy lines are taut and the tent wrinkle free. Loosen guy lines when moisture causes the tent to shrink.

c. Large General Purpose Tent.

- (1) Erect liner (para.4-12).
- (2) Operate stovepipe openings. Refer to paragraph a. (3) above.
- (3) Install three stoves (TM 10-4500-200-13).
- (4) Keep all doors closed except when entering or exiting the tent.

d. Winter Climatic Conditions.

The use of tent steel pins is authorized in winter climatic conditions when temperature falls below freezing or for erection on hard ground. Authorization is as follows:

Small Gen. Purpose Tent, NSN 8340-00-823-7451, 12" long, 29 each

Med. Gen. Purpose Tent, NSN 8340-00-823-7451, 12" long, 28 each

Large Gen. Purpose Tent, NSN 8340-00-823-7451, 12" long, 32 each

Med. Gen. Purpose Tent, NSN 8340-00-261-9749, 9" long, 68 each

Large Gen. Purpose Tent, NSN 8340-00-261-9749, 9" long, 48 each

2-13. Operation in Extreme Heat.

a. All tents.

- (1) Erect liner (para. 4-12).
- (2) Ventilate with all available ventilators.
- (3) Roll and tie sidewalls opposite direct rays of sun. Change after midday. Raise all sidewalls after sundown.

b. Large General Purpose Tent. Open windows. Refer to paragraph 2-11.

2-14. Operation In Windy, Sandy, and Dusty Areas.

- a. Keep all guy lines and ventilator lines taut and secure to prevent damage by winds.
- b. Keep doors and ventilators securely closed, sidewalls down, and footstops secure, to limit sand or dust entry, and avoid damage by winds.

2-28.1/(2-28.2 blank)

2-15. Operation Under Rainy Conditions.

- a. Frequently check all guy lines and loosen at tent slip as required, to prevent damage caused by moisture weight or shrinkage.
- b. Ditch around walls sufficiently deep to direct water away from tent.

2-16. Operation in Snow.

- a. When snow is falling, sweep or brush it from roof frequently before accumulated weight damages tent.
- b. Keep alert to moisture conditions and adjust all guy lines at tent slips as required before weight or shrinkage damages tent.
- c. Pile snow on ground (snow) cloth of small tent to keep drafts from entering tent.

CHAPTER 3
 OPERATOR MAINTENANCE

	Page
OVERVIEW	3-1
SECTION I. Lubrication Instructions	3-1
SECTION II. Operator Troubleshooting	3-1
SECTION III. Operator Maintenance Procedures	3-3

OVERVIEW

The lubrication instructions, troubleshooting and operator maintenance procedures contained in this chapter provide data for unit support personnel to use and maintain the general purpose tent. The instructions and procedures apply to the small, medium and large general purpose tent, unless noted otherwise.

Section I. LUBRICATION INSTRUCTIONS

Paragraph	Page
3-1 General	3-1
3-2 Lubrication Instructions	3-1

3-1. General. Lubrication instructions for the tent, general purpose (large, medium, or small) are covered in paragraph 3-2.

3-2. Lubrication Instructions. The slide fastener closure of doors, corners, or window panes will require frequent lubrication to prevent sticking, locking, or other difficulty in operation. Lubricate the interlock scoops with stick form zipper-ease lubricant contained in Tentage Repair Kit, until slider moves freely for full length of fastener.

Section II. OPERATOR TROUBLESHOOTING

Paragraph	Page
3-3 General	3-1
3-4 Troubleshooting	3-2

3-3. General.

a. This section contains troubleshooting information for locating and correcting most of the troubles which may develop in the tent, general purpose (large, medium, or small).

b. This manual cannot list all malfunctions that may occur, nor all tests or inspections and corrective actions. If a malfunction is not listed or is not corrected by listed corrective actions, notify your supervisor.

3-4. Troubleshooting. In table 3-1, each malfunction listed is followed by inspections which will help you to determine probable causes and corrective actions to take. You should perform the inspections and corrective actions in the order listed.

Table 3-1. Operator Troubleshooting.

MALFUNCTION	TEST OR INSPECTION	CORRECTIVE ACTION
-------------	--------------------	-------------------

1. SLIDE FASTENER HARD TO OPERATE.

Step 1. Check for dirt in scoops.

Clean by using a soft bristle brush, then lubricate (para. 3-2).

Step 2. Check for dry or slightly corroded fastener.

Clean with soft bristle brush, then lubricate (para. 3-2).

Step 3. Check for crushed slider.

Report to unit maintenance.

2. RIDGE PLATE (OR RIDGE POLE) DOES NOT FIT SQUARELY ON UPRIGHT.

Check for bent or missing spindle.

Straighten spindle or replace upright pole.

3. LINER TOO CLOSE TO TENT BODY ROOF.

Step 1. On small tent, check adjustment of straps in peak.

Adjust.

Step 2. On large and medium tents, check tension of suspension lines at ridge and eaves.

Adjust.

4. EAVE AND CORNER GROMMETS RIPPING OUT WITH REGULARITY

Step 1. Check for old and worn fabric.

Replace tent.

Step 2. Check tension of lines in wet weather.

Loosen at tent slips more frequently.

Table 3-1. Operator Troubleshooting (cont).

MALFUNCTION	TEST OR INSPECTION	CORRECTIVE ACTION
-------------	--------------------	-------------------

Step 3. Check tension of lines during windy weather.

Tighten at tent slips more frequently during windy periods.

5. TENT PINS PULLED UP.

Check tension of lines during heavy rains.

Reset pins with poles angled slightly towards tent to allow for stretching and shrinking. Adjust lines at tent slips more frequently.

6. TENT LEAKING.

Step 1. Check for hole in fabric.

Mark and report to unit maintenance for patching.

Step 2. Check condition of water repellent.

Report defect to unit maintenance.

Section III. OPERATOR MAINTENANCE PROCEDURES

Paragraph	Page
3-5 Protection of Tent Against Damage	3-3
3-6 Protection of Pins, Poles, and Lines Against Damage	3-4

3-5. Protection of Tent Against Damage.

a. *General.* Probably the greatest amount of damage to tents are caused by carelessness, such as forgetting to loosen the lines when it starts to rain, not bothering to use spark arrestors or draft diverters, adjusting lines carelessly, driving pins in a slipshod manner, or dragging tents over rough ground. To prolong the life and usefulness of a tent, the following rules should be observed.

- (1) Inspect tent at frequent intervals to make sure that it is in serviceable condition. Particular attention should be given to seams, bindings, lines, and all places where strain is exerted.
- (2) Be constantly on the lookout for:
 - (a) Any evidence of mildew.
 - (b) Any foreign matter which may have collected on the tent.

- (c) Small rips and holes, splitting of seams, grommets which have become loose, lines which are beginning to rot, or anything else which does not appear to be in normal condition.

b. Protection Against Rain.

- (1) All tents are water repellent. However, rain causes tent canvas and lines to shrink, the shrinkage often becoming sufficient to tear the tent. Tents have been torn completely in two under such circumstances.
- (2) Before tent lines become water soaked, they should be loosened sufficiently so that when they shrink they will not become tight enough to tear the tent. To compensate for shrinkage, eave and corner lines should have a free swing of approximately 18 inches at the middle of the line.

- c. Protection Against Wind. In a strong wind, all lines should be tightened immediately, door entrances closed, walls secured to footstep pins, and all corners closed.

d. Protection Against Fire.

- (1) The general purpose tents are fire resistant. This does not mean that they will not burn: they usually do not burst into flame, but smolder and char.
- (2) When using a stove in a tent, every precaution must be taken to avoid fires. Spark arrestors or draft diverters must be installed and shields placed around stovepipe opening. All personnel should be well trained in building and maintaining stove fires and should be familiar with all fire regulations.
- (3) Whenever possible, fire extinguishers containing water should be kept in the tent area.

e. Protection Against Mildew.

- (1) The general purpose tents are mildew resistant. This does not mean that they are not subject to mildew. Under warm and damp conditions, especially in tropical and jungle areas, if proper care is not taken, tents may be ruined by mildew in a few days.
- (2) Keep tent clean at all times. If tent is pitched under trees, inspect the tent roof frequently to see if it is being harmed by drippings from branches or leaves. The growth of fungi and mold is caused to some extent by tree drippings, oils, greases, and starches, which accumulate on tents.

3-6. Protection of Pins, Poles, and Lines Against Damage.

- a. Pins. Care should be taken in handling pins to see that they are not broken or otherwise damaged. In determining the serviceability of pins, look for cracks, splits, distorted ends, and broken or flattened points.
- b. Poles. Care should be taken in handling tent poles to see that they are not broken or otherwise damaged. In determining the serviceability of poles, look for cracks, splits, condition of metal joiners, and missing or bent spindles.
- c. Lines. Lines should be inspected frequently. The stability and safety of the tent may depend upon the condition of the various lines used. Deterioration in tent lines is of two kinds: physical and chemical. Physical damage is caused by surface wear or from internal friction between the fibers. Chemical damage is caused by exposure to weather conditions and acids. To prevent damage to tent lines, observe the following rules:

- (1) Dry lines properly after exposure to dampness. Lines are best dried when hung loosely between two trees or other objects so that they do not come in contact with the ground.
- (2) Keep lines clean. If lines become dirty, they should be washed in clean water and thoroughly dried. Grit from sand, mud, or other materials, if allowed to remain and work into lines, will grind and wear the fibers.
- (3) Protect lines from chemicals. Keep lines away from chemical or their fumes, especially acids or alkalis. Drying oils, such as linseed oil, and paint will also damage lines.
- (4) Slack off guy lines. When guy lines or other supports are exposed to the weather, slack them off to prevent overstrain because of shortening from wetting.
- (5) Replace lines which reflect wear that may decrease breaking strength.

NOTE

Tent lines without adequate breaking strength for high winds and safety of personnel will not be used.

- (6) Whip ends of lines to prevent raveling.

CHAPTER 4

UNIT MAINTENANCE INSTRUCTIONS

	Page
OVERVIEW	4-1
SECTION I. Repair Parts, Special Tools, TMDE and Support Equipment	4-1
SECTION II. Service Upon Receipt	4-2
SECTION III. Unit PMCS	4-21
SECTION IV. Unit Troubleshooting	4-22
SECTION V. Unit Maintenance Procedures	4-24
SECTION VI. Preparation for Storage or Shipment.....	4-20

OVERVIEW

This chapter provides information for preventive maintenance and troubleshooting of general purpose tents by unit level maintenance personnel.

Section I. REPAIR PARTS, SPECIAL TOOLS, TMDE AND SUPPORT EQUIPMENT

Paragraph	Page
4-1 Common Tools	4-1
4-2 Special Tools, TMDE and Support Equipment	4-1
4-3 Repair Parts	4-1

4-1. Common Tools. A complete list of common tools and tool kits is given in Section III of Appendix B, Maintenance Allocation.

4-2. Special Tools, TMDE and Support Equipment. There are no special tools or equipment needed to maintain the tents.

4-3. Repair Parts. Repair parts for unit maintenance of the shelters are listed and illustrated in TM 10-8340-211-23P.

Section II. SERVICE UPON RECEIPT

Paragraph		Page
4-4	Unpacking	4-2
4-5	Inspection	4-2
4-6	Servicing the Equipment	4-2
4-7	Site Selection	4-2
4-8	Pitching Tents in Snow	4-3
4-9	Erecting of Small General Purpose Tent	4-4
4-10	Erecting of Medium General Purpose Tent	4-7
4-11	Erecting of Large General Purpose Tent	4-9
4-12	Equipment Conversion	4-11
4-13	Trenching Around Tent	4-20

4-4. **Unpacking.** (figure 4-1) Unpack tent from truck Or from pallet using a suitable lifting device. Check that the bandings are secure before unpacking, to avoid accidents. Remove bands (1) and tent (2) from pallet (3). Remove cover (4) from tent body. Check that pins and poles (5) are present. Then perform preventive maintenance checks and services (table 2-1).

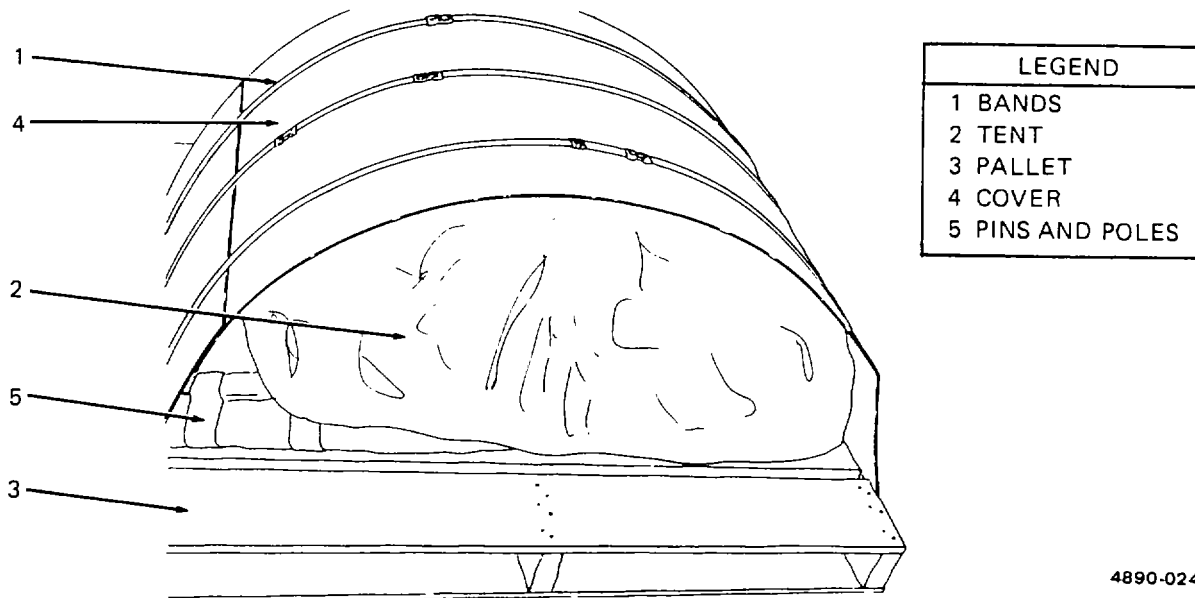

Figure 4-1. Small General Purpose Tent, Packed for Shipment.

4-5. Inspection. Inspect tents and make sure they are thoroughly dry. When wet tents must be folded, be sure they are marked for opening and drying at the earliest opportunity.

4-6. Servicing the Equipment. Lubricate the equipment as described in para. 3-2.

4-7. Site Selection. Consider the following points when selecting a tent site:

- a. The ground should be level and free from projecting roots and rocks. When such a spot is not available, a place can often be leveled and cleaned. In woods, moss and rocks can be used to level the ground.

- b. The ground should be high enough for good drainage.

NOTE

Drainage can be improved by trenching around the tent and digging an outlet ditch to direct water in the desired direction.

- c. The site should be protected from wind and storm.
- d. An area with a ground cover of tough turf grass is desirable.
- e. The tent should be placed far enough from rivers and lakes so that it will be above the high-water mark
- f. During hot weather, when possible, select a site that will provide ample shade.
- g. In woods, the location should be away from dead trees.

- h. In mountainous country, the tent should not be placed in a canyon or next to a dry creek bed. Such places can fill with rushing torrents in a short time. The tent should not be placed at the base of a cliff or steep mountainside, where there may be danger from avalanches or falling rocks.

- i. On snow-covered ground, prod surface with an ice or ski pole to see whether snow conceals any crevices. It may be impossible to find an area entirely without crevices, but by knowing where they are it is possible to avoid accidents. Pack snow hard by stamping on it with skis or snowshoes, or shovel top snow off until firm snow is found below.

- j. Discretion should be exercised when installing tent pins in winter climatic conditions where the temperature falls below freezing. In areas where winter conditions prevail the use of the 12 inch steel tent pins (NSN 8340-00-823-7451) is required rather than the 9 inch aluminum pins furnished with erection kits. Attempt to install the aluminum pins under winter conditions will only result in bending and breaking the pins.

4-8. Pitching Tents In Snow.

- a. Pitch tent so that entrance is not directly downwind. If the tent is pitched on snow with the entrance directly downwind, the entrance may become blocked, since snow tends to pile up in the lee of any object.

- b. Site is not temporary, dig tent into snow. This will provide better protection from the wind. In open terrain with a strong wind it may be necessary to build a snow wall on the windward side of the tent to protect it from the wind; thus the tent is easier to heat and is less likely to blow down. Leave some space between sides of tent and snow wall to have room to shovel out snow that may drift into tent.

- c. When a tent is pitched on a slope, a horizontal platform should be formed. The snow which is removed may be packed around the outer edge of the platform to widen the space for the tent.

- d. High winds, common in cold weather regions, require that tents be anchored securely. Tent pins may not provide sufficient anchorage. General purpose small tents have snow cloths sewed along the bottom edge of tent walls. When the small tent is set up, snow cloths should be flat on the ground outside the tent. Place snow, snow or ice blocks, stones, logs, or other heavy objects on the cloths to help anchor the tent.

- e. Do not attempt to drive tent pins into hard, frozen ground if the force required is excessive. Instead, chop small holes into the ground, insert tent pins into holes, and fill holes with slush or water; in a short time the tent pins will be firmly anchored. When removing pins from frozen ground, always chop them out; never hammer them sideways to break them loose.
- f. Snow carried into a tent will melt and wet sleeping bags and clothing. The following precautions should be taken to keep snow out of tents:
 - (1) Each man must take care to brush all snow from his clothing and boots before entering a tent.
 - (2) One man should enter the tent first and take the sleeping bags, packs, and other articles from the other man after the items have been brushed off completely.

4-9. Erection of Small General Purpose Tent.

- a. Unpack tent (para. 4-4), then perform preventive maintenance check and services (table 2-1).
- b. Study the ground plan (figure 4-2) carefully before erecting tent.

CAUTION

Lift tent body up off ground when removing guy lines from under it, and avoid possible damage to screen doors.

- c. Refer to figure 4-3 (View A) and spread tent on ground so that doors are in the desired position.
- d. Close front (1) and rear (2) doors by fastening snaphooks to matching D-rings on inside of door (3), close both slide fasteners, then fasten outside snaphooks in matching D-rings (4).
- e. Drive footstop pins (5) (fig. 4-3) at the six corners, two at each door (6), then attach footstop line (7) to each pin.

NOTE

Never angle a tent pin away from tent. Drive 9 inch aluminum pins or 12 inch steel pins straight up-and-down. Pins angled away from tent have more leverage from the tent line. When canvas gets wet and shrinks, the pin acts like a lever and enlarges the hole, loosening the pin.

- f. Measure 11 ft 8 in. from each corner, mark distance, then check that a line between each two directly opposite corners is a straight line. Drive 9 inch aluminum pins straight up and down in mark, then attach the six corner eave lines to pins (8, View B).
- g. Unsnap front door snaphook from D-ring (4) on outside, open slide fastener (9), then enter tent with center pole adjusted to 10 ft. 6 in.
- h. Position point of center pole (10) in peak plate, raise center pole and tent body (11) until pole is vertical, then tighten corner eave guy lines (8) just enough to hold center pole (9) upright.
- i. Adjust the two door eave poles (12 View C) to 7 ft., adjust the six corners eave poles (13) to 5 ft., then insert spindle of poles in grommet provided, and raise each pole to the vertical as it is positioned in the grommet. Tighten the corner eave guy lines (8).

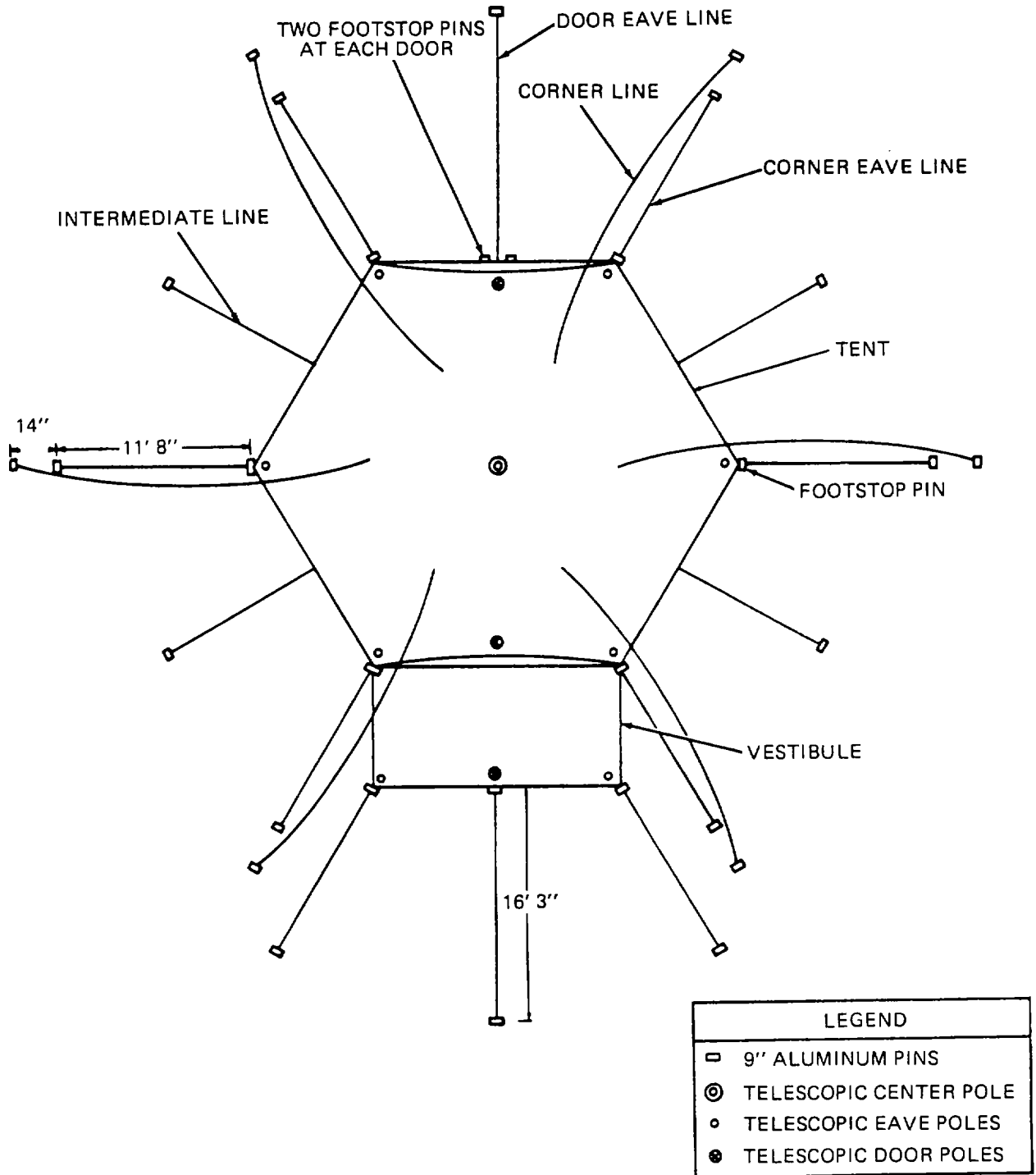

Figure 4-2. Ground Plan of Small General Purpose Tent (Includes Vestibule).

4-9. Erection of Small General Purpose Tent (cont).

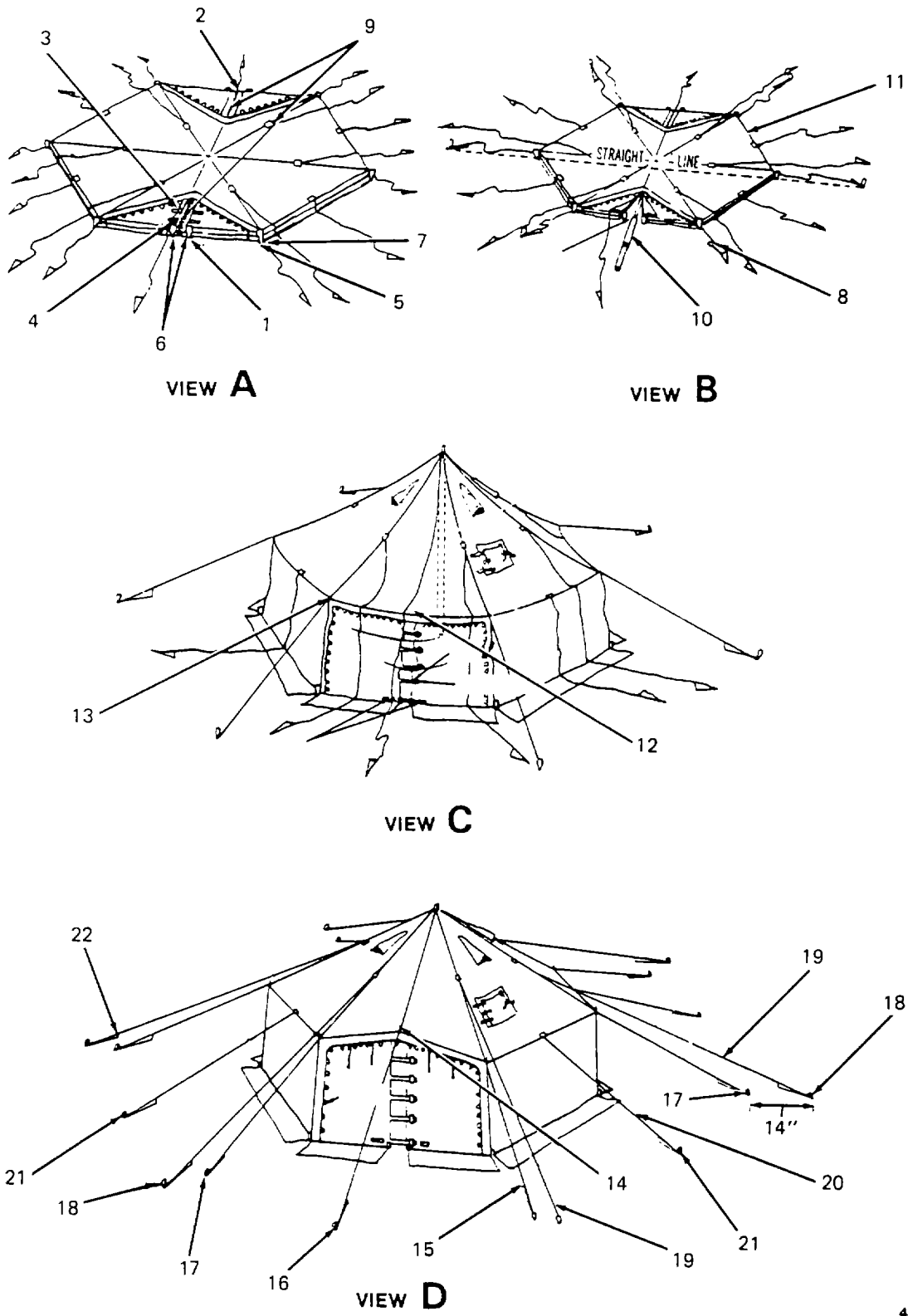

Figure 4-3. Erection of Small General Purpose Tent.

4890-026

- j. Measure 16 ft. 3 in. from front door eave pole (14), drive pin, then fasten door eave guy line (15) to pin (16). Repeat for rear door eave guy lines.
- k. Measure 14 in. beyond each corner eave guy line pin (17, View D), drive another pin (18), then fasten remaining corner lines (19) to these pins.
- l. Measure 11 ft. 8 in: from tent at the four intermediate eave guy lines (20), drive pins (21), then fasten intermediate eave guy lines to pins.
- m. Tighten all guy lines at slip (22) until tent body is free of wrinkles. Tent is now erected.

4-10. Erection of Medium General Purpose Tent.

- a. Unpack tent (para. 4-4) perform preventive maintenance checks and service (table 2-1).
- b. Study the ground plan (figure 4-4) carefully for placement of poles and pins.
- c. Refer to figure 4-5 and position tent as shown in view A, so that corners are square.
- d. Slide fasteners (1) at the four corners.
- e. Drive a 16 inch footstop pin (2) straight up and down at each corner and attach end wall and side-wall corner footstop (3) to pins.

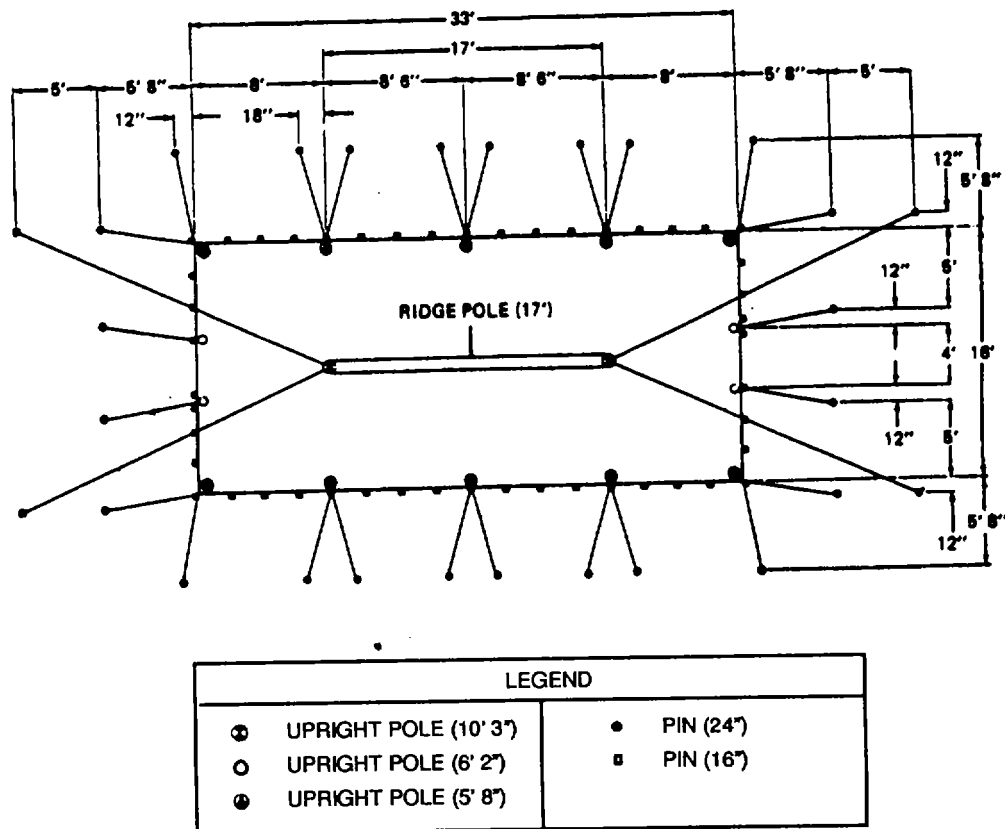

Figure 4-4. Ground Plan of Medium General Purpose Tent.

4-10. Erection of Medium General Purpose Tent (cont).

NOTE

Never angle a tent pin away from the tent. Drive 16 inch wood pins straight up-and-down. Drive 24 inch wood pins at an angle about 15 degrees from vertical toward the tent. Pins angled away from the tent have more leverage from tent line. When the canvas gets wet and shrinks, the pin acts like a lever and enlarges the hole, loosening the pin.

- f. Use a five foot eight inch eave pole (4) as a measure to place pins equidistant from sidewall according to ground plan (figure 4-4), mark and drive 24 inch wood pins (5), then attach side (6), corner (7), and door eave (8) guy lines to pins.
- g. Insert spindles of five foot eight inch eave poles (4) in grommets at eave and corner. Insert six foot two inch door poles (9, View B) in grommets of front and rear doors.
- h. Raise tent walls by raising all eave, corner, and door poles (4, View A and 9, View B) to a vertical position. Then tighten all guy lines (6, 7, 8, View A) just enough to keep poles and sidewalls upright.
- i. Assemble the two joined center poles (10) and the joined ridge pole (11), then from inside the tent, position them as shown in view C (figure 4-5) with spindles of center poles (12) through ridge pole plates and grommets in roof.
- j. From outside tent, attach ridge guy lines (13) to spindles of center poles and to pins.
- k. From inside tent with one man at each center pole (14, View D), raise them to a vertical position, then tighten ridge guy lines (15).
- l. From outside tent, assure that all guy lines are attached to pins and tightened and all footstops (16) are attached.

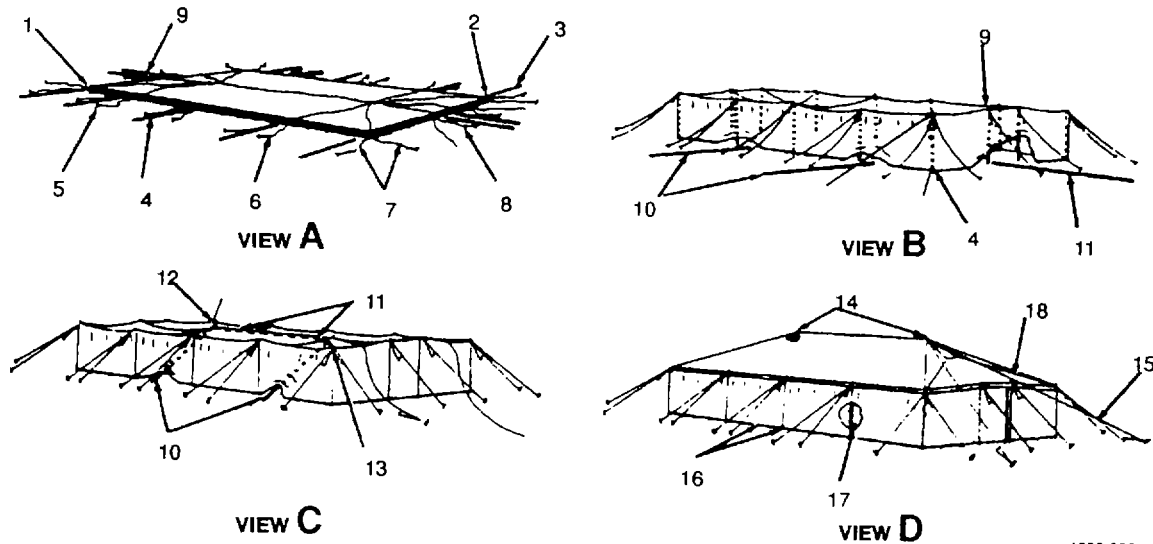

Figure 4-5. Erection of Medium General Purpose Tent.

NOTE

Be sure all poles are straight before tightening the guy lines just tight enough to remove all wrinkles from roof.

- m. Drive 16 inch pins at remaining side and end wall footstops at a slight angle, about 15 degrees from vertical, toward the tent, and attach footstops (16) to pins.
- n. Working inside tent, tie jumper lines (17) to side, corner, and eave poles.
- o. Adjust ventilator flap lines (18) and tie them to corner eave poles.
- p. Fasten tie tapes at inside corners of tent around corner eave poles. Tent is now erected.

4-11. Erection of Large General Purpose Tent.

- a. Unpack tent (para. 4-4) then perform preventive maintenance checks and services (table 2-1).
- b. Study the ground plan (figure 4-6) carefully for placement of poles and pins.

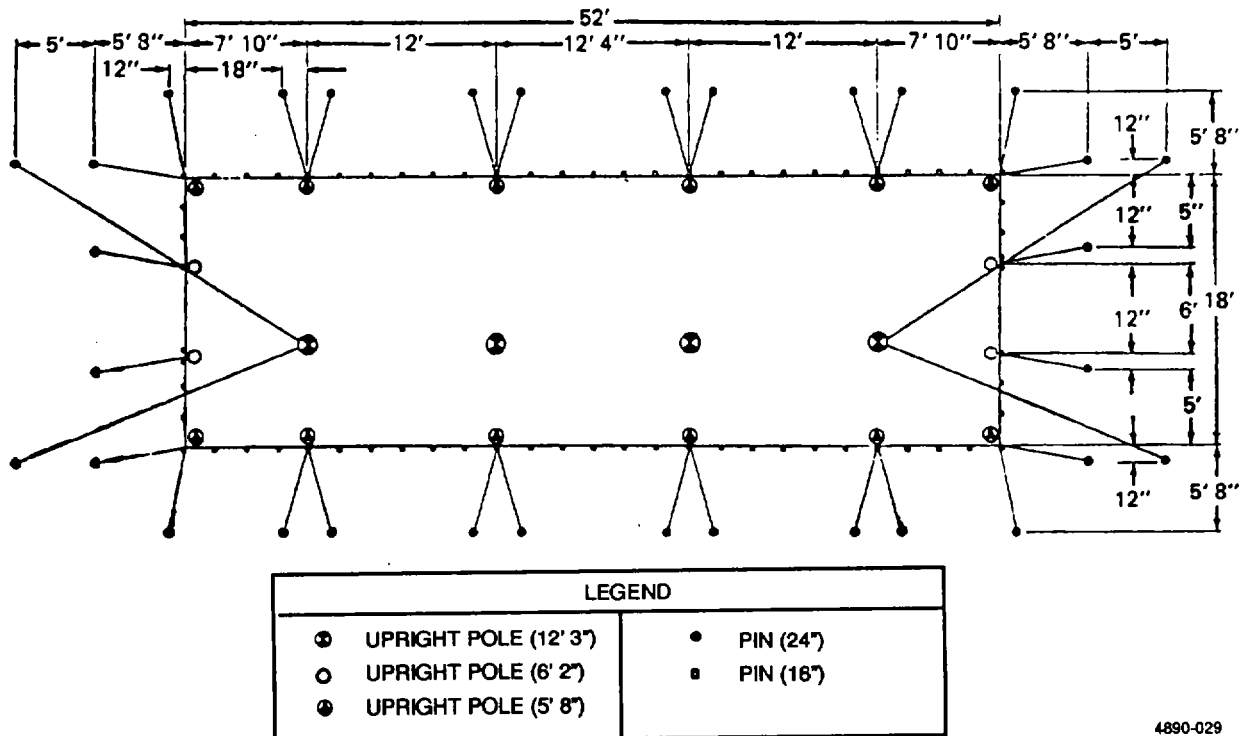

4890-029

Figure 4-6. Ground Plan of Large General Purpose Tent.

- c. Refer to view A, figure 4-7, and position tent flat on ground so that corners are square.
- d. Slide fasteners (1) at all tent corners.
- e. Drive 16 inch pins (2) straight up and down at each corner and attach end wall and sidewall footstops (3) to pins.

4-11. Erection of Large General Purpose Tent (cont).

NOTE

Never angle a tent pin away from the tent. Drive 16 inch wood pins straight up-and-down. Drive 24 inch wood pins at an angle about 15 degrees from vertical toward tent. Pins angled away from the tent have more leverage from the tent line. When canvas gets wet and shrinks, the pin acts like a lever and enlarges the hole, loosening the pin.

- f. Use length of 5 ft. 8 in. eave pole (4) as a measure in placement of pins equidistant from walls as shown in ground plan (figure 4-6), mark and drive 24 inch pins (5) then attach side (6), corner (7), and door eave lines (8) to pins.
- g. Insert spindles of 5 ft. 8 in. eave poles (4) in grommets in eaves and at corners, insert spindles of 6 ft. 2 in. door poles (9) in grommets of front and rear doors.
- h. Refer to view B and raise tent walls by raising all eave, corner, and door poles (4,9) to a vertical position, then tighten all guy lines just enough to hold walls and poles upright.
- i. Assemble the four jointed center poles (10) and from inside tent, position them as shown in view C, with spindles through ring and grommet (11) in roof.

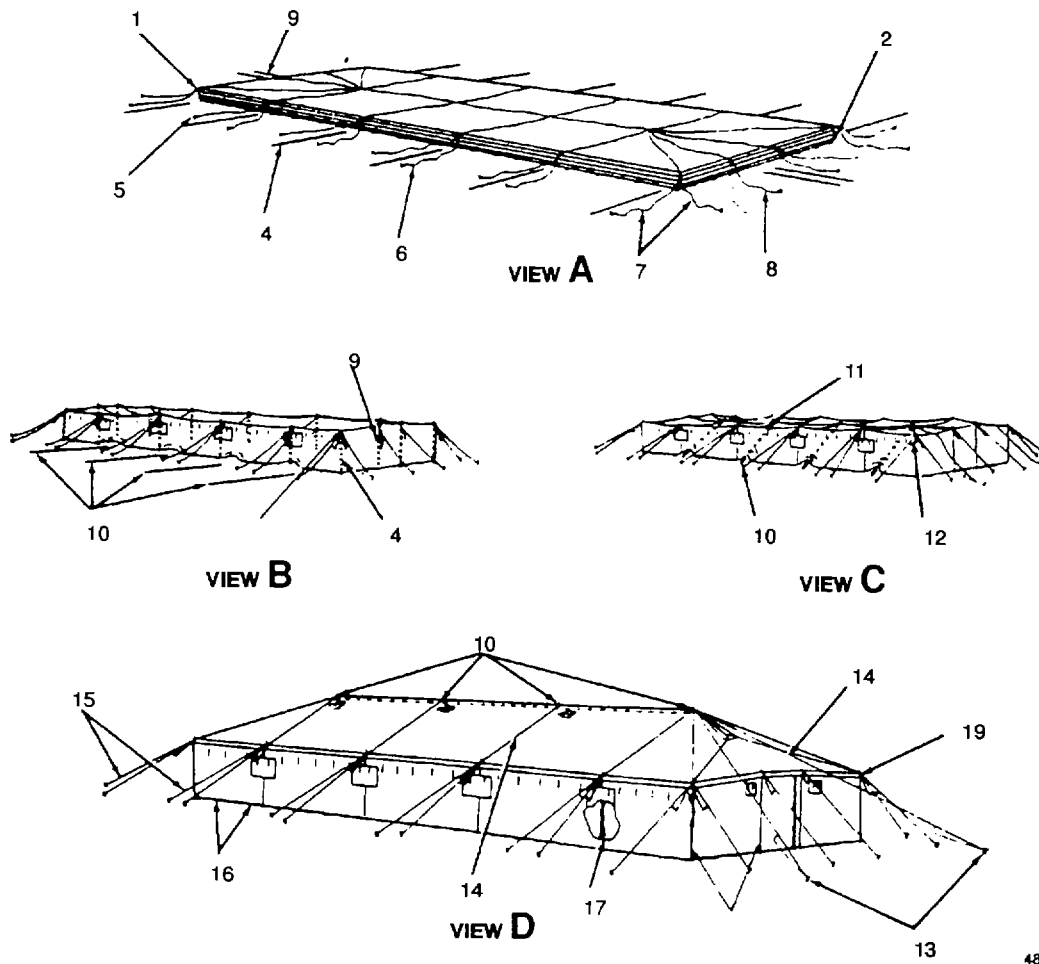

4890-030

Figure 4-7. Erection of Large General Purpose Tent.

- j. From outside tent attach ridge guy lines (12) to spindles of pole at each end, then to pins (13, View D).
- k. From inside tent, with one man at each center pole (10), raise them to a vertical position, then tighten ridge guy lines (14).
- l. From outside tent assure that all guy lines (15) are attached to pins and tightened.

NOTE

Be sure all poles are straight before tightening the guy lines just tight enough to remove wrinkles from roof.

- m. Drive 16 inch pins at remaining side and endwall footstops at a slight angle, about 15 degrees from vertical, toward tent and attach footstops (16) to pins.
- n. Working inside tent, tie jumper lines to side, corner and door eave poles, and center poles.
- o. Adjust ventilator flap lines (18) and tie them to corner eave poles (19).
- p. Fasten tie tapes at inside corners of tent around corner eave poles. Tent is now erected.

4-12. Equipment Conversion.

- a. General. All tents may be converted for extreme heat or cold weather operation by the installation of liners. The small tent may be further converted for cold weather operation by erection of a vestibule at the front door. Two small tents may also be erected in tandem, when more floor space is required.
- b. Erection of Liner in Small Tent (figure 4-8). The small tent liner is erected inside small tent as follows:
 - (1) Loosen all corner, intermediate, and door eave guy lines.
 - (2) Spread liner on ground inside tent.
 - (3) Lower peak of tent, remove center pole spindle (1) from ring (2) in peak and position it under liner (3) with spindle of pole through hole in liner, then through supporting ring (2) in peak of tent.
 - (4) Lift center pole enough to free liner for movement, line up door, stovepipe (4), and ventilator
 - (5) openings of liner with similar openings in tent. Then tie tapes (6) of liner stovepipe shield
 - (7) to corresponding tapes of tent body to keep openings in place.
 - (5) Insert D-rings at peak of liner (8) into the appropriate snap hooks (9) near peak plate of tent.
 - (6) Lift center pole to a vertical position, then tighten all corner, intermediate, and door eave guy lines (para. 4-9).
 - (7) Insert all metal toggles (10) inside tent through matching grommets in roof of liner. The toggle chapes will allow approximately two inches between tent body liner, for insulation purposes; when adjusting straps (11), hold liner high enough so that liner weight keeps toggle chapes at full length.

4-12. Equipment Conversion (cont).

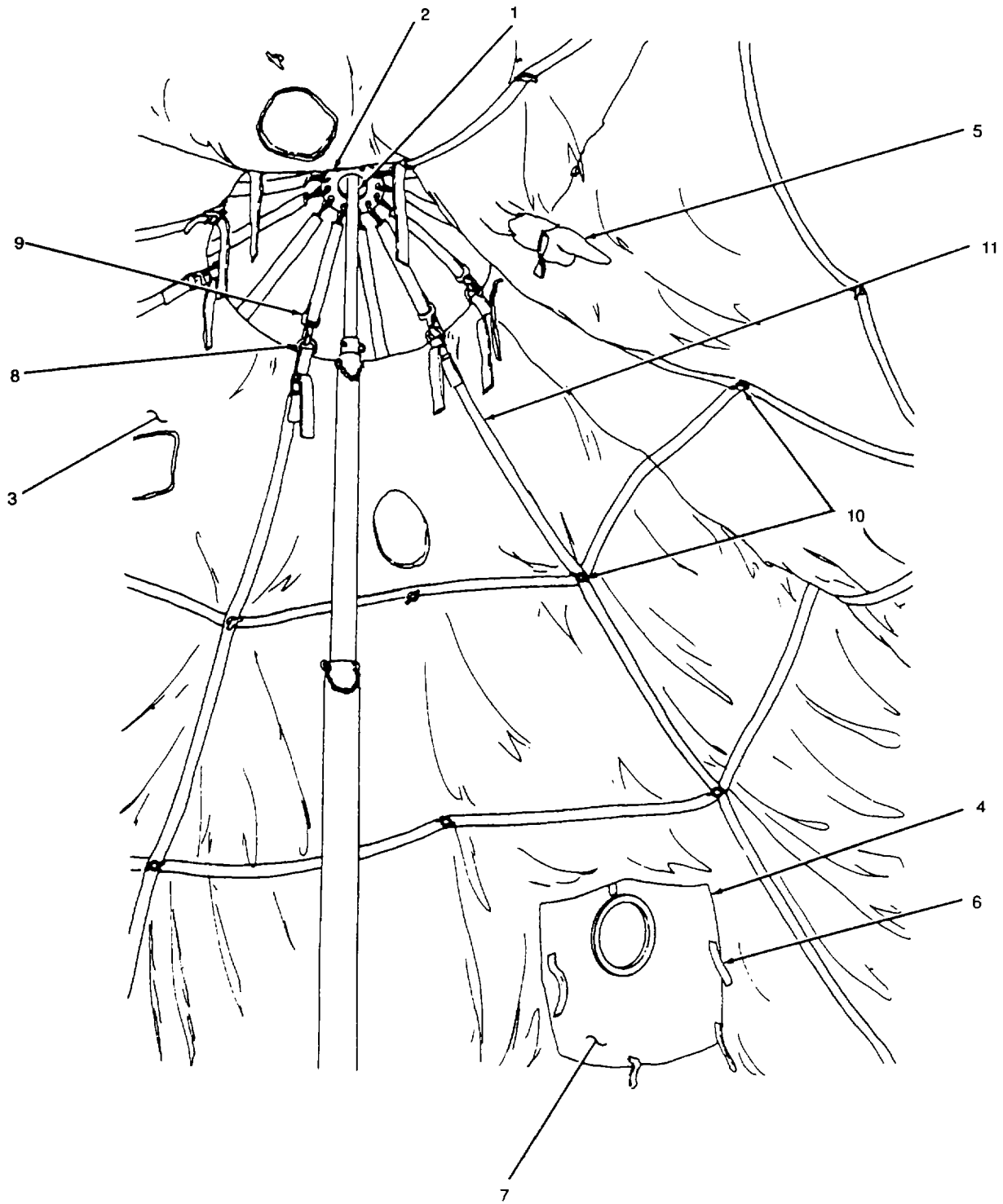

4890-031

Figure 4-8. Small Tent with Liner.

- (8) Tie the tapes of liner to screen door tapes, remove tent sidewall footstops from footstop pins, secure liner sidewall screen and liner sidewall footstops on footstep pins, then secure tent footstops on footstep pins.
- (9) Assure that guy lines are tight at slip, and tent body is wrinkle free.

c. Striking and Folding Liner of Small Tent (figure 4-8).

- (1) Remove tent sidewall footstops from footstop pins (para. 4-9), remove liner sidewall and liner sidewall screen footstops from footstop pins, then reinstall tent sidewall footstops on footstop pins. Untie liner tie tapes from screen tie tapes.
- (2) Loosen all corner, intermediate, and door eave guy lines slightly by adjusting the tent slips.
- (3) Lower liner (3) and peak of tent slightly by moving center pole off the vertical, remove all toggles (10) from grommets in liner and untie tapes (6) at stovepipe openings, then unsnap snaps from D-rings (8) at peak and allow liner to fall to ground.
- (4) Lift center pole (1) off ground, pull liner (3) under pole, then position center pole at the vertical, and tighten all guy lines at tent slips.
- (5) Move liner out of tent to a dry area suitable for folding, then fold liner in a manner similar to that described for tent body in paragraph 4-32.

NOTE

When liner is being struck because of conversion back to mild weather operation, after folding liner, deliver it to unit supply for storage. If striking it for movement to a new worksite, liner may be stacked on tent body before cover is closed and secured.

f. Erection of Liner in Medium Tent. (figure 4-9) Erect liner in medium tent as follows:

- (1) Loosen all guy lines (1, view A) at tent slips (2).
- (2) Unfold liner (3, view B) on one side of center poles (4) inside tent so that liner stovepipe openings are on same side as openings in tent body (5).
- (3) Lift each center pole and pull portion of liner under poles until poles will go through sleeves of liner (6, view C), then spread liner out on floor (view C).
- (4) Use a ladder for height and tie liner ridge suspension lines (7, view D) to tent ridge plates and ridge pole, then wrap liner pole sleeves around the center poles and tie with tapes (8).
- (5) Tie tapes at sides of liner doors to door eave poles.
- (6) Secure liner (9, view E) to doors, corners and wall eaves (10) by passing eave suspension lines of liner through hardware eye (11) on inside of tent (12), then run suspension lines (3) through grommets (13) in liner and secure to D-rings (14) of liner.

4-12. Equipment Conversion (cont).

(7) Remove tent footstops (15) from footstop pins. Secure liner screen (16) and sidewall footstops to footstop pins, then replace tent footsteps on footstop pins.

(8) Assure that all guy lines (17) are tight and that tent is free of wrinkles. Adjust guy lines at slips.

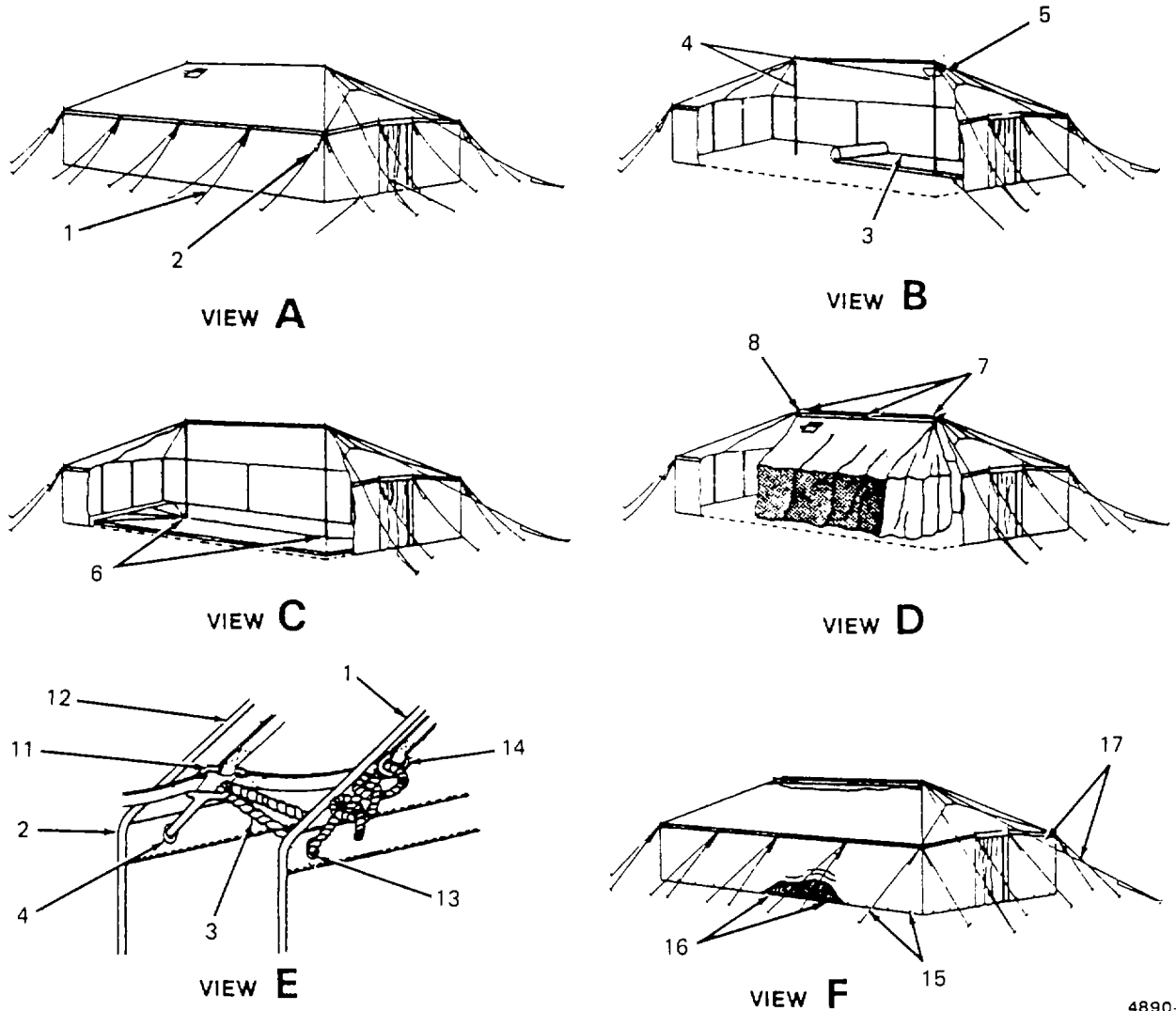

4890-032

Figure 4-9. Erection of Liner in Medium Tent.

g. Striking and Folding Liner in Medium Tent.

(1) Loosen all guy lines (17, figure 4-9) slightly at slips, remove tent footstops from footstop pins (15), remove liner sidewall and screen footstops (16) from footstop pins, then replace tent footstops on footstop pins.

(2) Untie tapes at corner and door eave poles.

(3) Untie and separate all liner eave suspension lines (3) from tent eaves.

- (4) Use a ladder for height and untie liner pole sleeves (8), and ridge suspension lines (7) from ridge pole and tent ridge plates, allowing the liner (3) to fall on ground.
- (5) Lift center poles enough to slide liner under poles and to one side of tent, then tighten all guy lines at slips.
- (6) Move liner outside tent to an area where it can be folded.
- (7) Refer to figure 4-10 and lay liner out as flat as possible, with eave suspension lines (1, view A) rolled and on top of liner (2). Fold side (3) and end (4) walls and sidewall screens under liner, then fold triangular ends of end walls over liner roof.
- (8) Fold ends of liner toward center (view B) with six-foot folds.
- (9) When liner is at six by sixteen feet, fold top and bottom ends in on center until liner measures three by six feet, then fold into a three by three foot package.
- (10) Lift three by three foot package on top of cover; then secure cover.

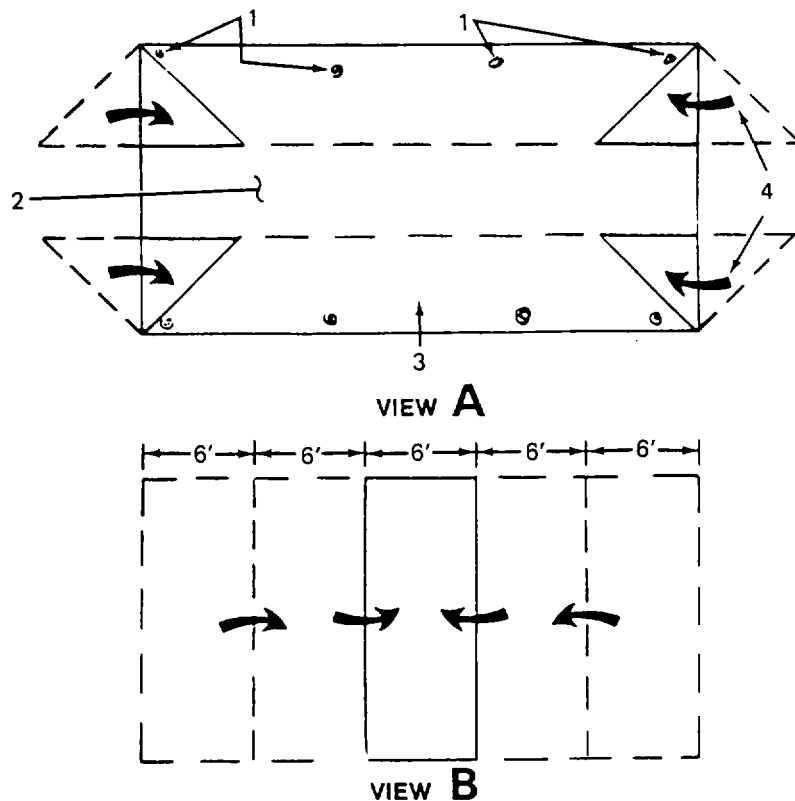
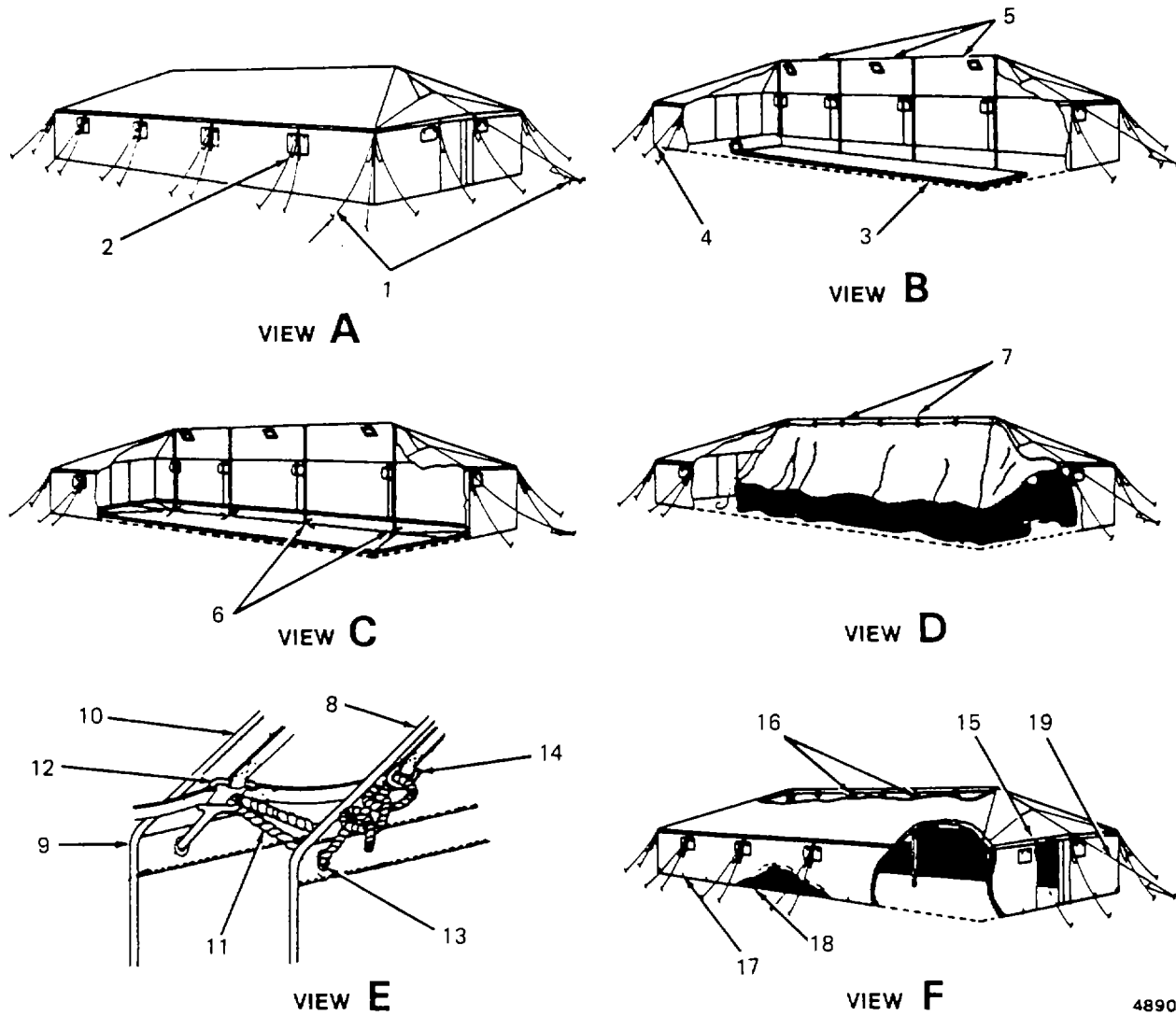

Figure 4-10. Folding the Medium Tent Liners.

h. Erection of Liner in Large Tent. (figure 4-11) Erect a liner inside the large tent as follows:

- (1) Loosen all guy lines (1, view A) slightly by adjusting slips (2).

4-12. Equipment Conversion (cont).



4890-034

Figure 4-11. Erecting Liner in Large Tent.

- (2) Unfold liner(3, view B) inside tent (4) so that stovepipe openings of liner are on same side as openings in tent (5).
- (3) Lift each center pole enough to work liner under and flat with ends of center poles through sleeves of liners (6, view C).
- (4) Use a step ladder for height and tie liner ridge suspension lines (7, view D) to tent ridge rings.

- (5) Secure liner (8, view E) to doors, corners, and wall eaves (9) of tent (10) by passing eave suspension lines (11) of liner through hardware eye (12) on inside of tent, then run suspension lines through grommets (13) in liner (8) and secure to D-rings (14) of liner.
- (6) Tie tapes at sides of liner doors to door eave poles (15, view F).
- (7) Use a ladder for height to wrap and tie liner pole sleeves (16) around center poles.
- (8) Remove tent sidewall footsteps (17) from footstop pins, secure liner sidewall screen and liner sidewall footsteps (18) to footstop pins, then reinstall tent sidewall footsteps to footstop pins.
- (9) Assure that all guy lines (19) are tight and that tent roofs, ends, and sidewalls are free of wrinkles. Adjust guy line slips accordingly.

i. Striking and Folding Liner in Large Tent.

- (1) Loosen all guy lines (19, figure 4-11) slightly at slips, remove tent wall footsteps (17) from footstop pins, remove liner sidewall and liner screen footsteps (18) from footstop pins, then reinstall tent wall footsteps on footstop pins.
- (2) Untie all tapes at corner and door eave poles (15), then use a ladder for height and untie tapes of pole sleeves (16) from center poles.
- (3) Untie and separate liner eave suspension lines (11) from tent body.
- (4) Use a ladder for height, untie ridge suspension lines (7) from ridge D-rings and allow liner to fall on the ground.
- (5) By moving slips (2), loosen all guy lines enough to allow center poles (6) to be lifted until liner (3) can be pulled under them to one side of the tent.
- (6) Refer to figure 4-12 and lay liner (1) out as nearly flat as possible, with sidewalls (2) and screens under liner, eave suspension lines (3) laid on top of liner, and triangular portions of end walls (4) folded back on roof.
- (7) Fold ends of liner toward center (view B), first with a three and one half foot fold, then three succeeding folds of six foot each. The folded dimensions of liner at this point are approximately six by eighteen feet.
- (8) Make two folds as shown in view C, two more as shown in view D, then place folded liner on opened cover, view E.

NOTE

Be sure that folds allow all liner sidewall windows to lay flat in the final three foot dimension.

- (9) Close and secure cover over liner.

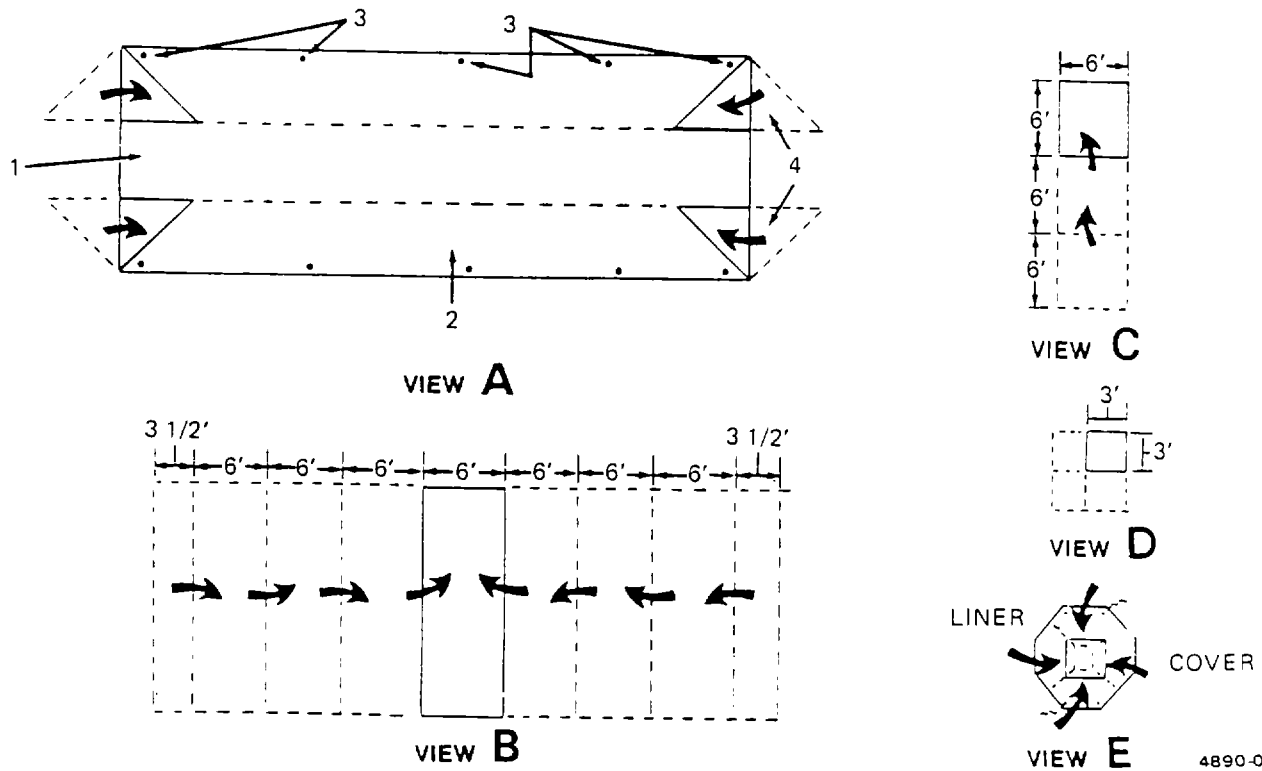

Figure 4-12. Folding the Large Tent Liner.

j. Erecting Vestibule on Small Tent. (figure 4-13)

- (1) Remove door guy line from door pole at tent door where vestibule is to be erected, then pull door guy line pin from ground.
- (2) The small tent door has two parallel fabric lugs all around its edge, a grommet lug and a becket lug. The vestibule has a grommet lug around the edge that joins the tent door. Fasten lugs of door and vestibule together by inserting grommet lug of vestibule (1, view A) between grommet lug and becket lug of tent, then chain-lace becket through grommets of vestibule and tent lugs. Begin chain-lacing at bottom (near ground) of lugs and continue until bottom (near ground) at other end of same lugs is reached, securing last becket with a knot (view B).
- (3) Drive vestibule guy line and footstop tent pins straight up and down as shown in ground plan (figure 4-2).
- (4) Attach vestibule guy lines to guy line tent pins.
- (5) Extend two eave poles to five foot length and insert spindles through grommets at corners of vestibule.
- (6) Extend one eave pole to seven foot length and insert spindle through center end grommet of vestibule eave (figure 4-2).
- (7) Tighten all guy lines. Adjust at tent slips as necessary.

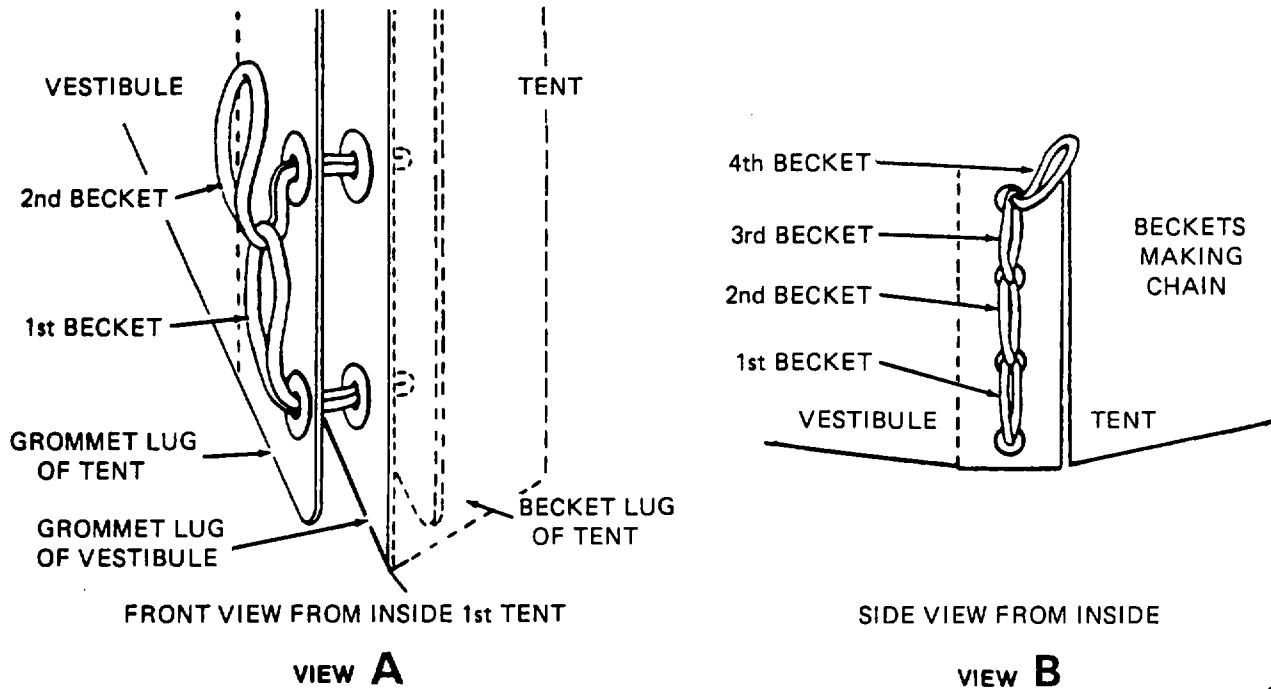

Figure 4-13. Joining Vestibule to Small Tent, or Two Small Tents in Tandem.

4890-036

k. Striking of Vestibule on Small Tent.

- (1) Loosen vestibule guy lines and remove from pins (figure 4-2). Remove vestibule footstops from footstop pins.
- (2) Remove three poles from vestibule and telescope them to their shortest length.
- (3) Unlace becketts and separate vestibule from tent.
- (4) Drive pin and attach door guy line (figure 4-2).

l. Erection of Two Small Tents in Tandem.

- (1) When two small tents are to be joined in tandem, erect the first tent as described in paragraph 4-9.
- (2) Fasten lugs at front (or rear) of tents in manner similar to that for vestibule to tent as described in j above using only the grommet lug of the second tent, then erect second tent (para. 4-9).

m. Striking of Two Small Tents in Tandem.

- (1) Unfasten lugs at front (or rear) of tents in manner similar to that for vestibule to tent as described in para. k.
- (2) Strike second tent and then first tent as described in para. 4-32.

4-13. Trenching Around Tent.

- a. A safe rule to follow is to always trench around a tent. When the tent is pitched on heavy soil, clay, or a flat rocky surface, a trench should always be dug. When the tent is set up on a very sandy soil, which absorbs water as fast as it falls, or when it is located on a mound which slopes off in all directions, a trench may not be necessary.
- b. Dig trench by cutting straight down just outside the footstop pins (figure 4-14); do not dig in a V-shape. Slope the side away from the tent. Dig trench all around the tent (figure 4-15).
- c. Throw dirt from trench away from the tent; never throw it against the tent, for it will quickly rot the canvas.
- d. In most cases, do not dig trench more than 4 or 5 inches deep and in the shallowest place not over 3 inches. There should be enough slope in the trench so that the water will flow freely toward the outlet and not back up.
- e. To carry the water off, dig an outlet (figure 4-15) at the lowest point of the area and connect it to the trench which has been dug around the tent.
- f. When there is a possibility that the water may flow in from higher ground, dig a ditch to divert the water before it can reach the tent.

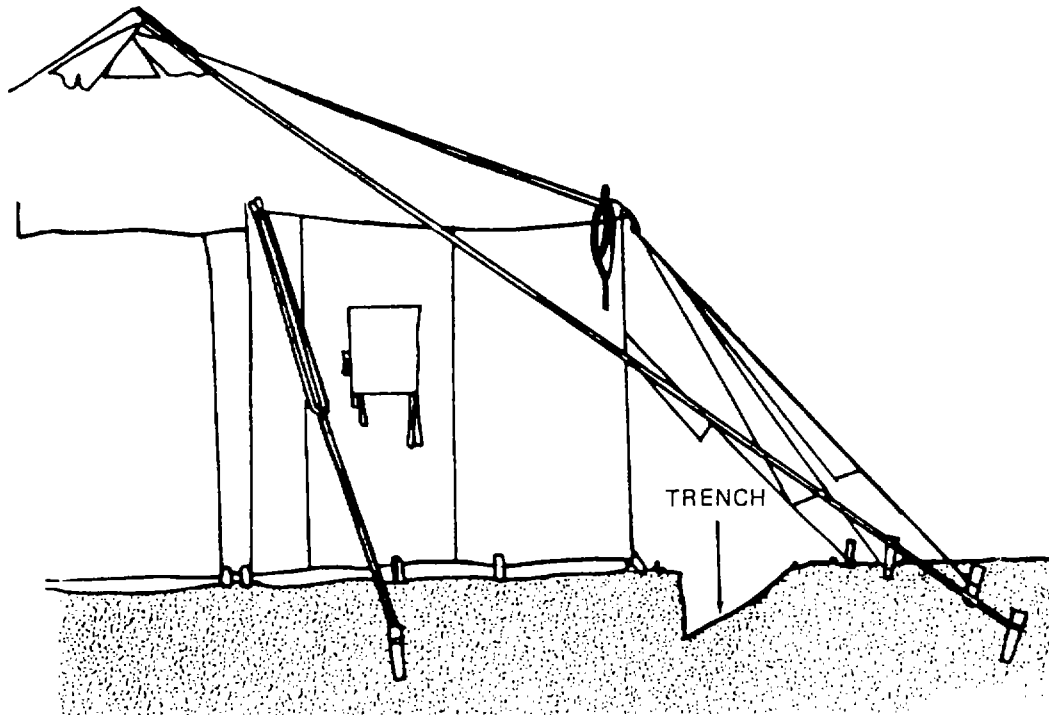

Figure 4-14. Cross Section View of Tent Trench.

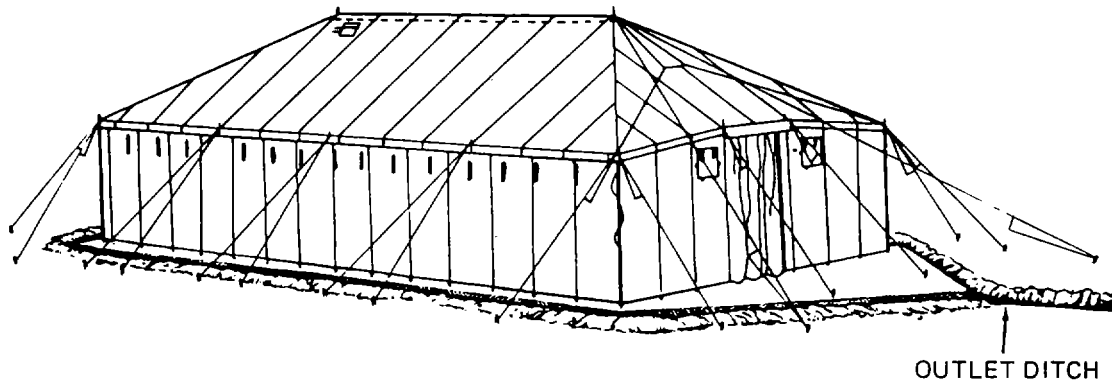

Figure 4-15. Trenching Around Tent.

Section III. UNIT PREVENTIVE MAINTENANCE CHECKS AND SERVICES

Paragraph	Page
4-14 General.....	4-21
4-15 Unit PMCS Procedures	4-21

4-14. General. Unit level maintenance PMCS are done to ensure that the tent is in top operating condition. A comprehensive PMCS program reduces equipment downtime and increases the operational readiness of the tent.

4-15. Unit PMCS Procedures. Unit level PMCS is contained in table 4-1. The numbers in the Item No. column show the order in which the check or service should be done. These numbers should be used when recording deficiencies and shortcomings on DA Form 2404, Equipment Inspection and Maintenance Worksheet. The • in the Interval column indicates when a check or service should be done.

NOTE

Tents which are in administrative storage condition should be inspected semiannually; however, the inspection should be limited to removing the cover to look for mildew, insects or rodent damage.

4-15. Unit PMCS Procedures (cont).

Table 4-1. Unit Preventive Maintenance Checks and Services (PMCS).

Q - Quarterly

S - Semiannually

Item No.	Interval		Item to be inspected	Procedures
	Q	S		
1	•		Tent Fabric	a. Repair small rips, tears, holes using repair kit (Appendix D). b. Clean off dirt, mildew or mud. Refer to para. 4-19. c. Treat fabric with preservative. Refer to para. 4-19.
2	•	•	Webbing	Repair by replacing loose or broken stitching using repair kit (Appendix D).
3	•		Slide Fasteners	Replace defective slide fasteners. Refer to para. 4-28.
4	•		Hardware	Report defective hardware to direct support maintenance.
5	•		Windows	Repair defective windows, tie tapes and stitching using repair kit (Appendix D).
6	•		Liner and Vestibule	Repair liner and vestibule by repeating checks 1 through 6. Repair small rips, tears and holes using repair kit (Appendix D). If there is extensive damage, report to next higher level of maintenance..

Section IV. UNIT TROUBLESHOOTING

Paragraph		Page
4-16	General.....	4-22
4-17	Troubleshooting	4-22

4-16. **General.**

This section will provide unit maintenance personnel with information useful in diagnosing and correcting unsatisfactory operation or failure of the general purpose tents (large, medium, or small.)

4-17. **Troubleshooting.**

Malfunctions of general purpose tents, or their components, which may occur are listed in table 4-2. Each malfunction stated is followed by probable cause of the trouble. The recommended corrective action is described opposite the probable cause.

Table 4-2. Unit Troubleshooting.

MALFUNCTION	TEST OR INSPECTION	CORRECTIVE ACTION
-------------	--------------------	-------------------

1. STOVEPIPE OPENING DEFECTIVE.

Step 1. Check for small crack in shield.

Report defect to next higher level of maintenance.

Step 2. Check for break, or section missing.

Report defect to next higher level of maintenance.

2. TENT LEAKING.

Step 1. Check for worn water resistant compound.

Brush or spray on new coating of compound (para. 4-19).

Step 2. Check for small hole in tent.

Patch using tent repair kit.

Step 3. Check for large hole in tent.

Report defect to next higher level of maintenance.

3. TENT WILL NOT STAY TAUT.

Step 1. Check for defective lines.

Replace defective lines.

Step 2. Check for torn eave over 2 inches or grommet pulled out.

Report defect to next higher level of maintenance.

Step 3. Check for missing hardware.

Report defect to direct support.

4-17. Troubleshooting (cont).

Table 4-2. Unit Troubleshooting (cont).

MALFUNCTION	TEST OR INSPECTION	CORRECTIVE ACTION
-------------	--------------------	-------------------

4. SLIDE FASTENERS LOCKED OR DEFECTIVE.

Step 1. Check for crushed slide.

Repair (TM 9-2865).

Step 2. Check for scoops bent or missing.

Repair (TM 9-2865).

Step 3. Check for torn tape head.

Repair (TM 9-2865) or report defect to next higher level of maintenance.

Section V. UNIT MAINTENANCE PROCEDURES

Paragraph		Page
4-18	General	4-24
4-19	Tent Body (Fabric)	4-25
4-20	Ventilator Flat Line (Small Tent)	4-28
4-21	Wood Toggles	4-29
4-22	Corner Hook.....	4-30
4-23	Grommets.....	4-31
4-24	Dual Eave, Corner and Door Guy Lines	4-32
4-25	Fairleads	4-34
4-26	Peak Plate	4-35
4-27	Ridge Plate	4-36
4-28	Slide Fasteners and Thongs	4-37
4-29	Vestibule (Small Tent).....	4-38
4-30	Liners.....	4-39

4-18. **General.** Unit maintenance personnel shall perform the maintenance functions described in this section as authorized by the Maintenance Allocation Chart. Components included under each entry in the component assembly column includes:

- a. Tent body (fabric, ventilator flap line, wood toggles, corner hook and grommets).
- b. Tent anchoring components (lines, fairleads, peak plate and ridge plate).
- c. Tent support components (slide fasteners and thongs).

d. Tent accessories (cover, cover strap, liner and vestibule).

4-19. Tent Body (Fabric).

This task covers: **Service**

INITIAL SETUP:

<i>Materials/Parts</i>	<i>Equipment Condition</i>
Compound Coating (Item 1, Appendix E) Dry Cleaning Solvent (Item 6, Appendix E) Soft-Bristled Brush (Item 4, Appendix E) Soap/Water (Item 3, Appendix E)	Tent Erected

Service (figure 4-16).

(1) *Cleaning.*

Remove dirt from fabric on all tent surfaces with a solution of mild soap and water applied with a soft-bristled brush, rinse with clean water. Wipe dry. Allow to dry thoroughly in sunshine before making repairs or placing in storage.

(2) *Fire, water, weather, and mildew resistant coating.*

(a) General.

When leaks are noted and fabric appears aged, the tent body (fabric) can be treated with compound coating, mildew, water, and fire resistant TT-P-595. It is furnished in paste-thick form, in five-gallon drums. For best results, make a mixture of 50 percent compound and 50 percent dry cleaning solvent, P-D-680 for either brush or spray on type applications.

CAUTION

Do not apply compound on a tent that is wet, dirty, mildewed, or has oil and grease spots on the fabric. (Stains are permissible.)

(b) Preparation.

- 1 When tent is not erected, erect it outside, or in a well-ventilated area.
- 2 Inspect for dirt, oil, grease stains, or mildew. If tent requires cleaning or patching, proceed as follows:
- 3 Refer to FM 10-16 and patch as required within organizational maintenance authorization.
- 4 Clean with a solution of mild soap and water applied with a soft-bristled brush, rinse, then dry thoroughly.

4-19. Tent Body (Fabric) (cont).

- 6 For estimating total quantity of mixture required for a tent, divide square feet of tent surface area to be covered by 90 (area one gallon will cover).
- 7 When solution is to be applied with a brush, use a whitewash type with a long handle.
- 8 When solution is to be applied with a spray gun, solution tank will require an air pressure of 30 psi, while the gun will require about 15 psi. Be sure air pressure source is adequate.

(c) Coating with fire, water, and mildew resistant compound.

WARNING

Be sure serviceable fire extinguishers are near, and ready for use. Do not smoke or allow open flame near the wet solution. When application is by either brush or spray, fumes are highly flammable. The compound contains a strong fungicide, so keep it off your skin or clothing. If some accidentally spills on skin, stop, wash it off immediately with warm soapy water. Always wear a respirator when solution is being sprayed on. Never spray while equipment used for food and drink is in the area. Fallout can be dangerous as well as distasteful.

NOTE

Be sure that the compound is applied evenly. If brushing, make strokes in all four directions. When spray is too heavy in certain areas, use a brush to smooth it out. Too much or too little compound is detrimental. Seams and patches must be covered well as this is where most protection from mildew is required.

- 1 Begin from top and move downward one panel at a time.
- 2 Treated fabric will dry to the touch in about 1/2 hour, but allow tent to dry in sun and air for at least 24 hours before folding and storage.

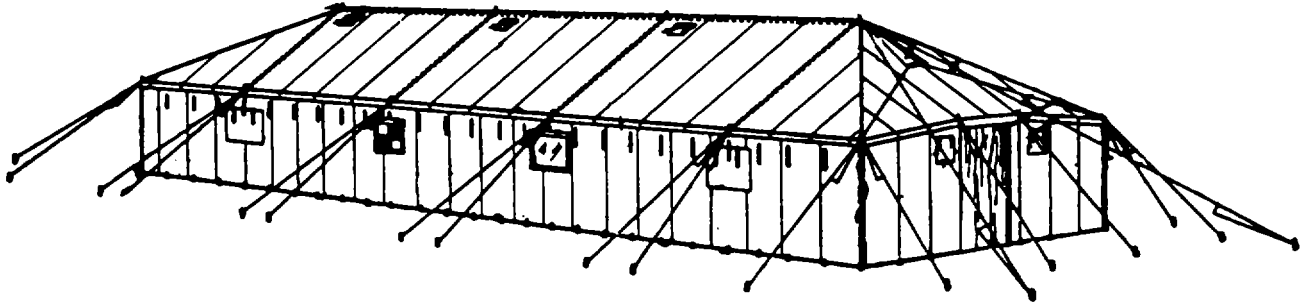

Figure 4-16. Tent Body.

4-20. Ventilator Flap Line (Small Tent).

This task covers: a. Service b. Replace

INITIAL SETUP:

Materials/Parts

Equipment Condition

Soft-Bristled Brush (Item 4, Appendix E)
Soap/Water (Item 3, Appendix E)
Nylon Cord (Item 7, Appendix E)

Tent Erected

a. Service (figure 4-17).

Clean all lines with a solution of mild soap and water applied with a soft-bristled brush. Rinse lines, wipe dry.

b. Replace.

- (1) Cut flap line (1) where it passes through grommet (2) and remove line.
- (2) Obtain a 12-foot nylon cord for each line to be replaced.
- (3) Tie a bowline knot (FM 10-16) so that it forms an eight inch loop at one end of line. Pass opposite end through flap grommet and then through eye of bowline knot. Pull the end of line tight. Secure end of line to spindle of proper eave pole.

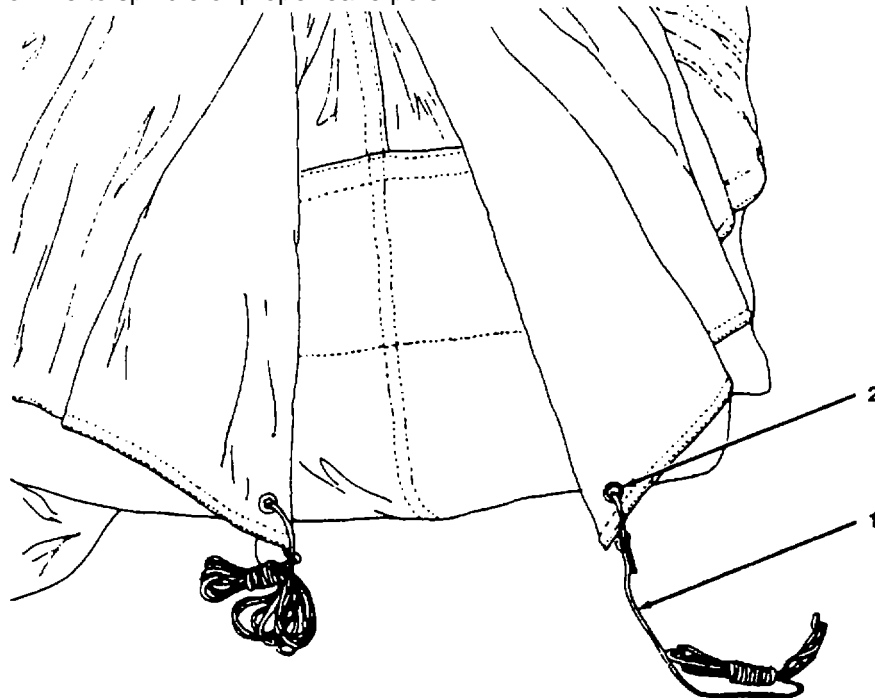

Figure 4-17. Ventilator Flap Line Replacement (Small Tent).

4-21. Wood Toggles.

This task covers: **Replace**

INITIAL SETUP:

Materials/Parts

Equipment Condition

Sailmakers needle (Item 5, Appendix E)

Tent Erected

Twine (Item 6, Appendix E)

Replace (figure 4-18).

- (1) Cut twine (1) holding wood toggle (2) to the tent body.
- (2) Obtain a 15-inch length of twine.
- (3) Pass end of twine through a sailmakers needle and hand sew wood toggle to the tent body by passing twine through the fabric and around notch of wood toggle several times.
- (4) Tie the ends of twine with a square knot (FM 10-16).

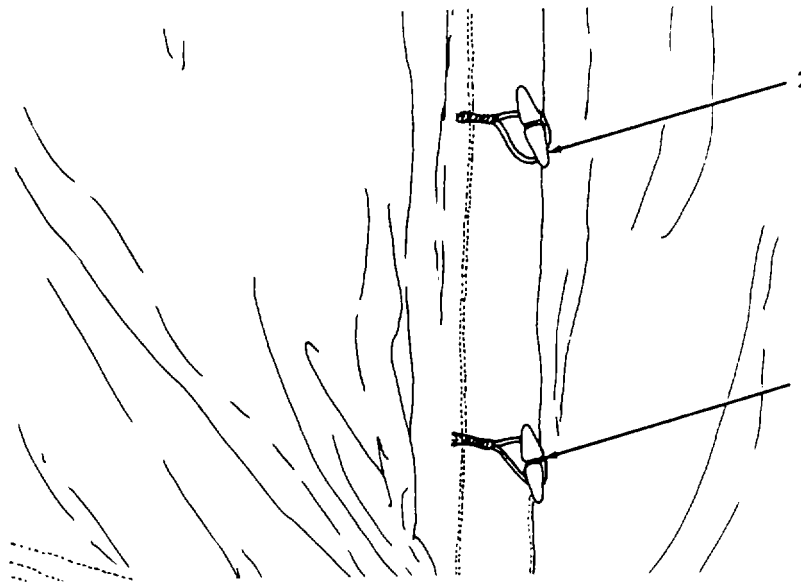

Figure 4-18. Wood Toggles.

4-22. Corner Hook (Shackle Type VI) Bolted (Medium and Large Tent).

This task covers: Replace

INITIAL SETUP:

<i>Tools</i>	<i>Equipment Condition</i>
Adjustable Wrench (Item x, Appendix E)	Tent Erected

Replace (figure 4-19).

- (1) Loosen corner guy lines at tent slip.
- (2) Open eye of hook and remove fairlead (para. 4-25).
- (3) Remove nut (1) and bolt (2), then remove corner hook (3) from chapes (4) and grommet (5).
- (4) Install bolt (2) through replacement corner hook (3), chape (4) and fasten with nut (1).
- (5) Attach fairlead and close hook.
- (6) Tighten corner guy line at tent slip.

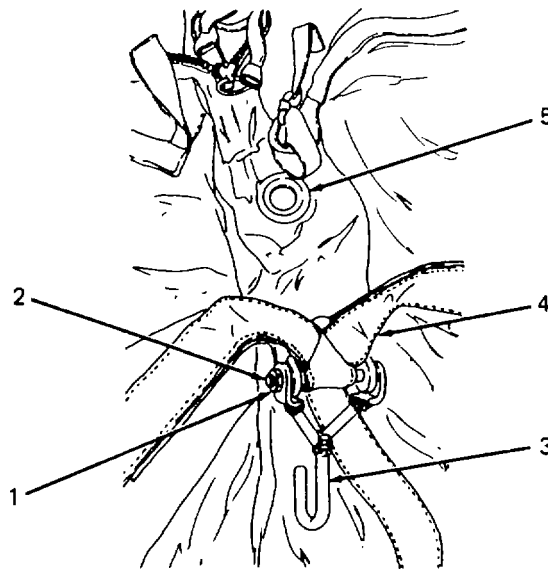

Figure 4-19. Corner Hook.

4-23. Grommets.

This task covers: **Replace**

INITIAL SETUP:

Equipment Condition

Tent Erected

Replace (figure 4-20).

- (1) For loose or missing grommet, install new grommet (1) as described in FM 10-16.
- (2) For grommets torn out, report to direct support maintenance personnel for machine sewing of patch or patches, then install grommets per (1) above.

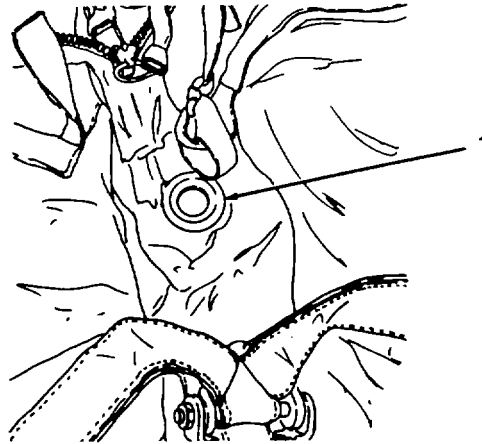

Figure 4-20. Grommets.

4-24. Dual Eave, Corner and Door Guy Lines,

This task covers: a. **Service** b. **Replace**

INITIAL SETUP:

<i>Materials/Parts</i>	<i>Equipment Condition</i>
Guy Lines (Appendix F) Soft-Bristled Brush (Item 4, Appendix E) Soap/Water (Item 3, Appendix E)	Tent Erected

a. Service.

Clean all lines with a solution of mild soap and water applied with a soft-bristled brush. Rinse lines, wipe dry.

b. Replace (figure 4-21).

- (1) Obtain proper replacement guy line (1).
- (2) Thread one end through tent slip (FM 10-16), fairlead (2) and through the other end of tent slip.
- (3) Tie an overhand knot (FM 10-16) in one end at tent slip. Make loop similar to a tied eye (FM 10-16) that will fit over tent pin.
- (4) Position loop over tent pin, then draw tent slip toward pin to tighten. Move tent slip toward eave to loosen.

NOTE

Remove and install all other similar lines as described above.

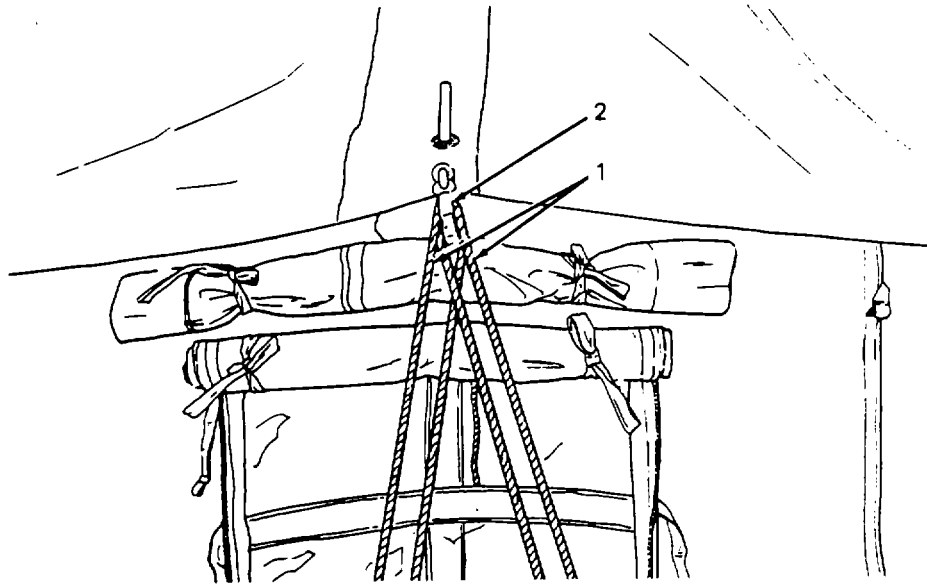

Figure 4-21. Dual Eave, Comer and Door Guy Lines.

4-25. Fairleads.

This task covers: **Replace**

INITIAL SETUP:

Equipment Condition

Tent Erected

Replace (figure 4-22).

- (1) Remove dual eave guy lines (1).
- (2) Open eye of hook (2) and remove fairlead (3).
- (3) Insert eye of replacement fairlead (3) in hook (2), then close hook eye.
- (4) Thread dual eave guy lines (1) through fairlead (3).

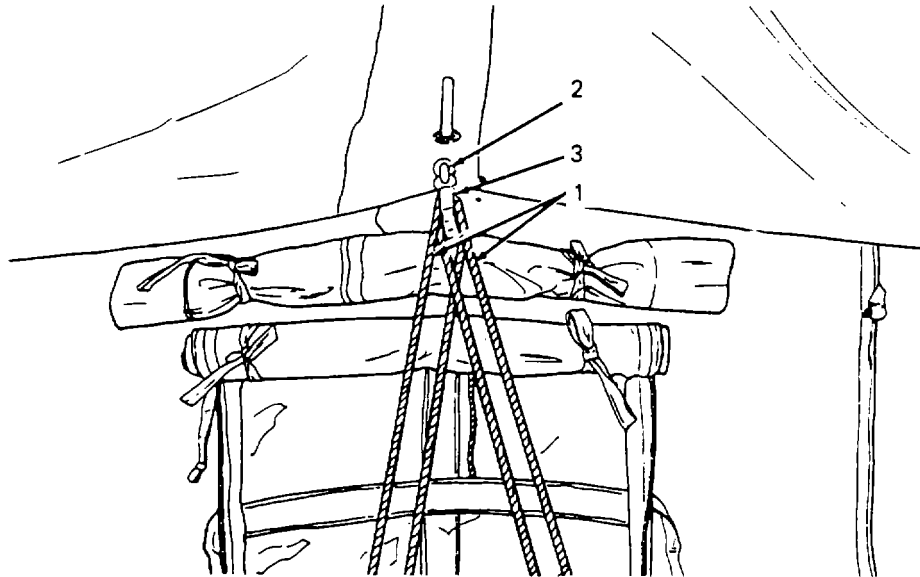

Figure 4-22. Fairleads.

4-26. Peak Plate (Small Tent).

This task covers: **Replace**

INITIAL SETUP:

Equipment Condition

Tent Erected

Replace (figure 4-23).

- (1) Loosen guy lines slightly, then lower tent peak by removing center pole (1).
- (2) Remove 12 snaphooks (2) from the peak plate (3), then remove peak plate.
- (3) Install snaphooks (2) in replacement peak plate (3).
- (4) Raise tent peak by raising center pole (1), then tighten guy lines.

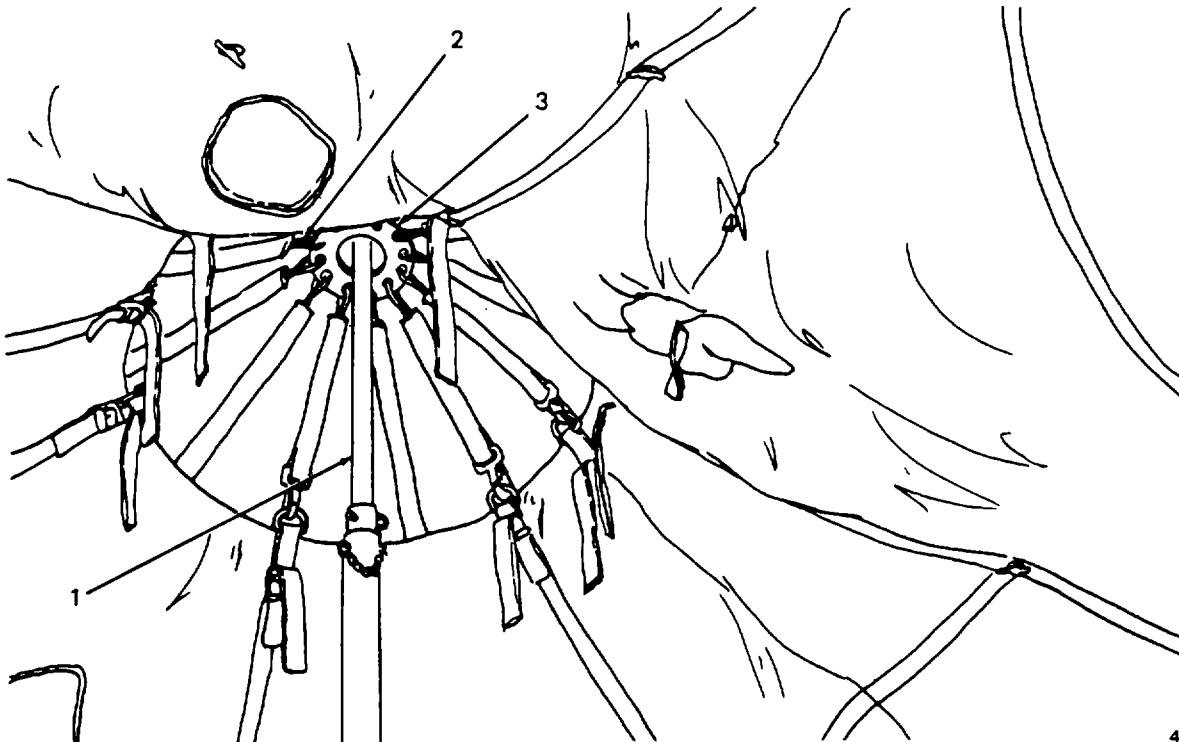

4890-046

Figure 4-23. Peak Plate.

4-27. Ridge Plate (Medium and Large Tent).

This task covers: Replace

INITIAL SETUP:

Equipment Condition

Tent Erected

Replace (figure 4-24).

- (1) Loosen guy lines slightly, then lower tent peak by removing center poles (1).
- (2) Remove hooks (2) from ridge plate (3), then remove ridge plate.
- (3) Install hooks (2) in replacement ridge plate (3).
- (4) Raise tent peak by raising center poles (1), then tighten guy lines.

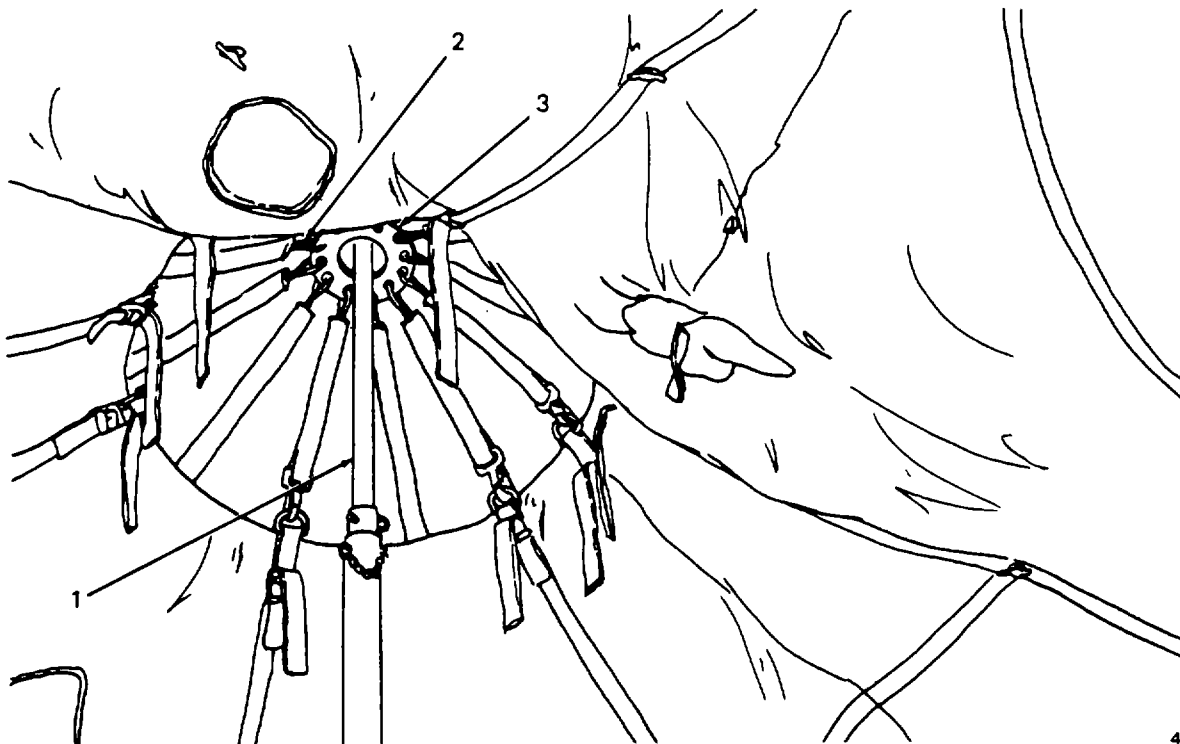

4890-046

Figure 4-24. Ridge Plate.

4-28. Slide Fasteners and Thongs.

This task covers: a. Service b. Replace

INITIAL SETUP:

Equipment Condition

Tent Erected

a. Service (figure 4-25).

Lubricate slide fastener (1) per paragraph 3-2.

b. Replace(Thong).

- (1) Cut defective thong (2) from wire stirrup of slider.
- (2) Fold thong (10-inch length of cord) in half.
- (3) Insert folded end through ring of slider, then put both ends through loop and draw tight.
- (4) Tie ends with an overhand knot (FM 10-16).

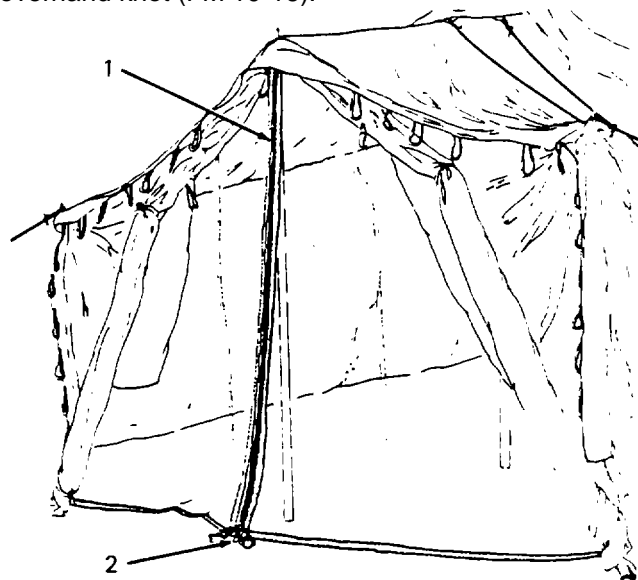

Figure 4-25. Slide Fasteners and Thongs.

4-29. Vestibule (Small Tent).

This task covers: a. Service b. Replace

INITIAL SETUP:

Equipment Condition

Vestibule Erected

a. Service

Clean and apply mildew proofing as for tent (refer to para. 4-19).

b. Replace (figure 4-26).

(1) Strike the vestibule (1), refer to paragraph 4-12).

NOTE

Perform minor repair to fabric as directed in paragraph 4-19, for grommets paragraph 4-23, lines paragraph 4-24 and slide fasteners paragraph 4-28.

(2) Report major defects to direct support maintenance.

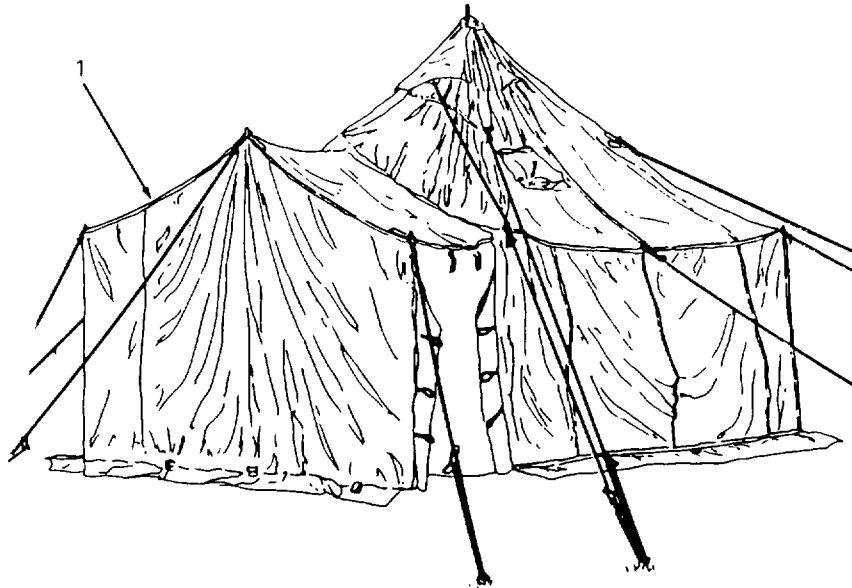

Figure 4-26. Vestibule.

4-30. Liner

This task covers: Service

INITIAL SETUP

Materials/Parts

Equipment.

Soft-Bristled Brush (Item 4, Appendix E)

Tent Erected.

Soap/Water (Item 3, Appendix E)

Service.

(1) Cleaning

a. General Purpose

Remove dirt from fabric on all tent surfaces with a solution of mild soap and water applied with a soft-bristled brush, rinse with clean water. Air dry.

b. Special Application or heavy soiled.

NOTE

This is for when liner must be cleaned for use in a mess or for medical application or when a liner becomes heavily soiled but is still serviceable condition.

Check the contract label on the liner and determine the date of manufacture. Liners manufactured prior to 1987 should be dry-cleaned only using standard industrial practices. Liners manufactured after 1987 can be dry-cleaned or laundered up to three times with only minor shrinkage (2%). Tumble or air dry on low heat to minimize shrinkage.

Section VI. PREPARATION FOR STORAGE EQUIPMENT

Paragraph		Page
4-31	General.....	4-40
4-32	Protection of Tent During Disassembly and Storage	4-40
4-33	Dismantling of the Small Tent.....	4-40
4-34	Dismantling of the Medium Tent	4-43
4-35	Dismantling of the Large Tent.....	4-44
4-36	Packing for Shipment and Storage.....	4-45
4-37	Administrative Storage.....	4-47

4-31. General. When dismantling tents for movement, always remove lines and vestibules first (figure 4-26). When dismantling and packing tent, always protect tent against damage.

4-32. Protection of Tent During Disassembly and Storage.

- a. Pitch, strike and fold tentage in the manner described in this manual. Do not try to take shortcuts unless you are sure no damage will be done. To protect the top of the tent during handling and in storage, fold the tent so that the sidewalls rather than the top of the tent will be exposed.
- b. Observe the utmost care when pitching and striking tent, making sure the material does not tear on protruding pins, overhanging branches, or other objects.
- c. Never drag tent along the ground or floor.
- d. Use all the necessary parts and accessories for the tent and use them for their intended purpose.

4-33. Dismantling Small Tent.

- a. General. Dismantling tents for movement to a new worksite consists of striking and folding, which are covered in this section.

CAUTION

Tents should not be folded unless they are thoroughly dry. When wet tents must be folded, be sure they are marked for opening and drying at the earliest opportunity.

- b. Striking and Folding the Small Tent (figure 4-27).
 - (1) If erected, strike and fold the vestibule (para. 4-12).
 - (2) If erected, strike the liner (para. 4-12).
 - (3) Loosen tent footsteps from footstop pins and pull footstop pins.
 - (4) Loosen door eave guy lines and remove door eave poles. Telescope poles to their shortest length.
 - (5) Remove door eave guy lines from pins and pull pins.

4-33. Dismantling Small Tent (cont).

- (6) Loosen all other guy lines and remove remaining eave poles. Then telescope poles to their shortest length.
- (7) Remove center pole and telescope to its shortest length.
- (8) Remove lines from all pins and pull pins.
- (9) Prepare tent for folding by engaging D-rings into snaps inside front and rear doors, close slide fasteners, then engage D-rings into snaps outside front and rear doors, and fasten toggles into toggle loops (figure 2-1).
- (10) Spread tent on ground and locate stovepipe opening (figure 4-27). Then grasp corner eave line to the right of opening and pull panel out (view A). Coil intermediate eave guy line, corner line, and corner eave line, neatly on panel (view A).
- (11) Reach to left of stovepipe opening, grasp corner eave line and pull second panel to the right, making an accordion fold (view B).
- (12) Make remaining folds in a similar manner (six folds in all), coiling lines neatly as each fold is made (views B and C).
- (13) Fold peak of tent about halfway to eave of tent (view C).
- (14) Fold right side of tent toward center to make a rectangle view (view D).
- (15) Fold tent to smallest possible size, then place tent on cover (view E).
- (16) Fold cover over and around tent and secure with straps, or lengths of rope.
- (17) Assemble and bundle pins and poles.

NOTE

Tent may now be transported to a new worksite nearby, and without further preparation, loaded for transport. In cases where worksite is more distant, one or more tents, poles and pins may be loaded on, and secured to a pallet with banding, for easier loading or handling.

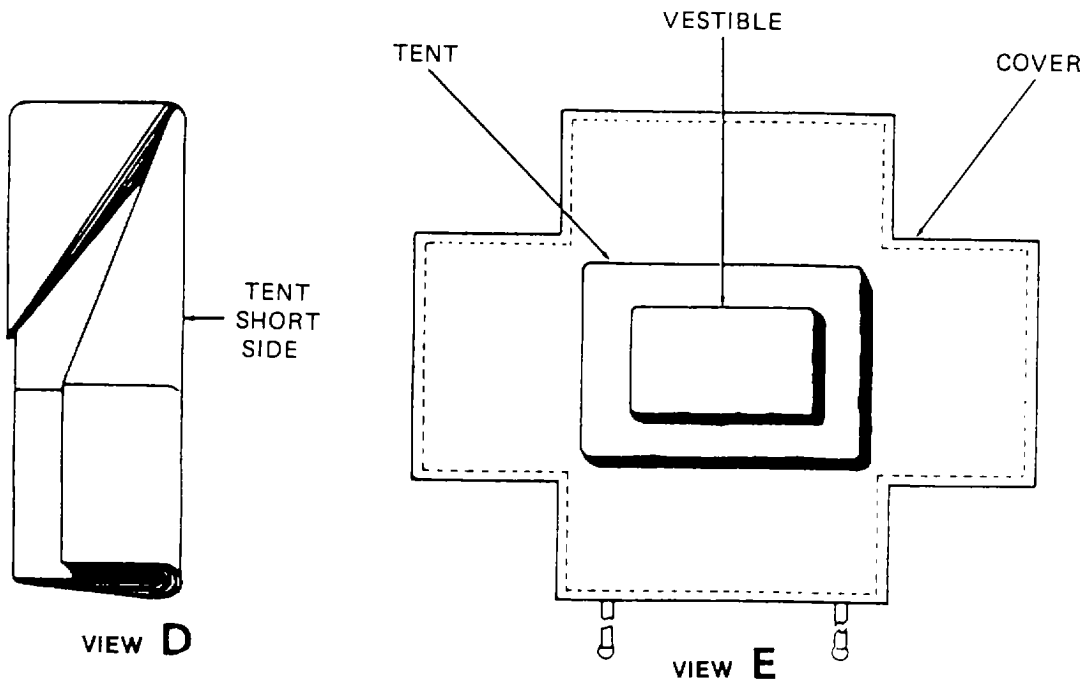
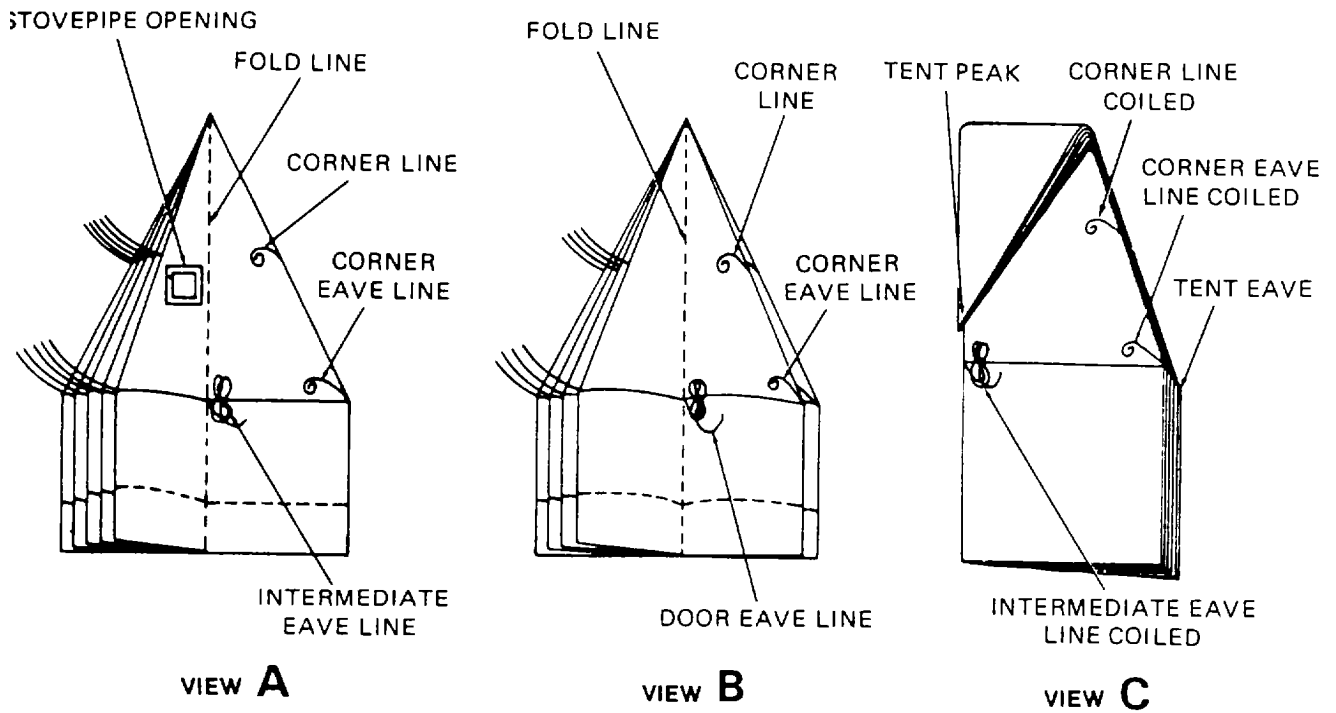

4890-050

Figure 4-27. Folding the Small Tent.

4-34. Dismantling Medium Tent.

- a. Striking and Folding of the Medium Tent (figure 4-28).
- (1) If erected, strike and fold liners (para. 4-12).
 - (2) Untie corner lug tie tapes then unwrap lugs from corner eave poles.
 - (3) Close doors and fasten wood toggles to toggle chapes.
 - (4) Untie jumper lines from center, eave, and door poles.
 - (5) Remove all footstop pins except those at each corner of the tent.
 - (6) Remove all eave guy lines from pins except those at corners of tent. Remove all unused pins.
 - (7) Remove door eave poles and all other eave poles except those at corners.
 - (8) Remove ridge guy lines from pins and lower center poles and ridge pole gently ground. Remove all unused tent pins.
 - (9) Remove center poles from ridge pole, then disassemble joined ridge and center poles.
 - (10) Remove the eight corner eave guy lines from pins, remove corner eave pole, then remove footstops from pins. Remove the remaining tent pins.
 - (11) Prepare tent for folding by opening corner slide fasteners, and closing stovepipe openings.
 - (12) Spread tent out flat as in (view A, figure 4-28) outside up, coil guy lines, and place them on tent roof. Fold end and sidewalls along eave line, onto roof of tent.
 - (13) Fold ends of tent toward center, making six foot folds as in (view B, figure 4-28). Fold one end of tent over the other.
 - (14) Folded tent is now six foot by sixteen foot. Fold each end toward center in three foot folds (figure 4-28), and lap one end over the other.
 - (15) Fold in half (three foot by three foot), position the folded tent on cover, then close and fasten cover securely. Bundle tent pins and poles in bundles of similar lengths.

NOTE

Tent is now ready for movement to nearby new worksite. When movement is more distant, tent may be palletized for ease of handling.

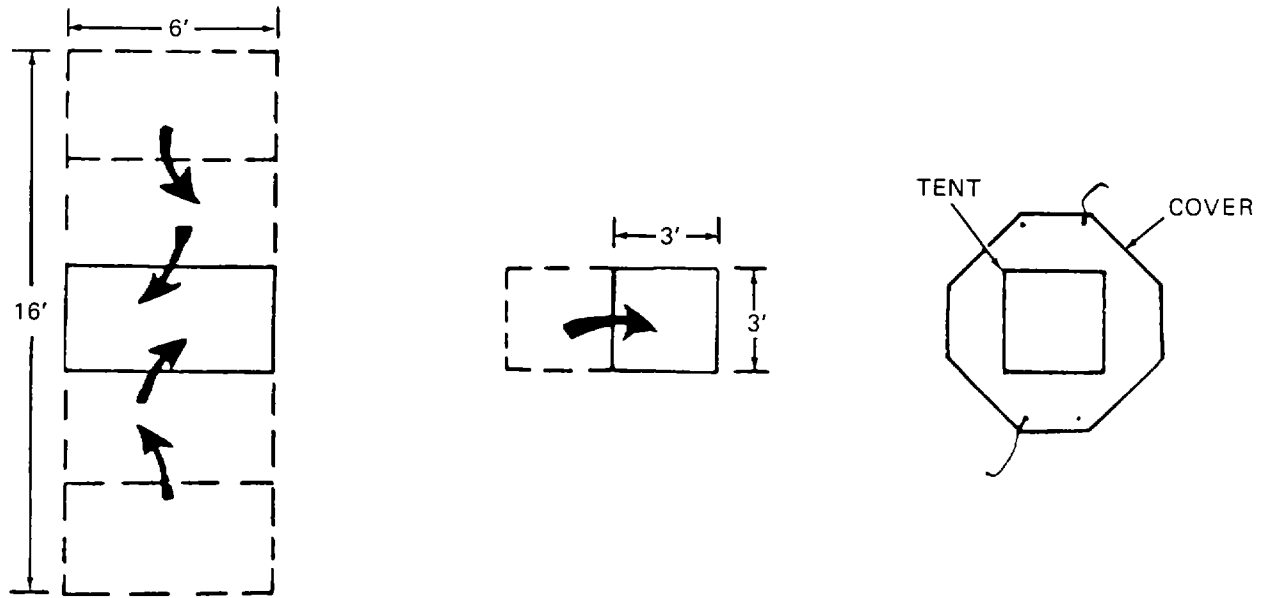

Figure 4-28. Folding the Medium Tent.

4890-051

4-35. Dismantling Large Tent.

a. Striking and Folding the Large Tent (figure 4-29).

- (1) If erected, strike the liner (para. 4-12).
- (2) Untie corner lug tapes and unwrap lugs from corner eave poles.
- (3) Close all windows by opening slide fastener, roll window pane, then secure with tie tapes. Close doors and fasten toggles to toggle chapes.
- (4) Use a ladder and untie jumper lines from center poles, then from eave and door poles.
- (5) Remove all footstop pins except those at each corner of the tent.
- (6) Remove all eave guy lines from guy line pins except those at tent corners, then remove all unused guy line pins.
- (7) Remove door eave poles and all other eave poles except those at tent corners.
- (8) Remove ridge guy lines from tent pins and lower center poles gently to the ground. Remove all unused tent pins. Remove and disassemble jointed poles.
- (9) Unfasten the eight corner eave guy lines from guy line pins, remove corner eave poles, remove footstops from pins, then remove all remaining tent pins.

4-35. Dismantling Large Tent (cont).

- (10) Prepare tent for folding by opening corner slide fasteners, then close and secure stovepipe openings.
- (11) Spread tent out flat (figure 4-29), outside up, then coil guy lines and place them on tent roof.
- (12) Fold end and sidewalls, along eave line, on tent roof (view A, figure 4-29).

CAUTION

Be sure that fold lines do not come at windows when folding this tent.

- (13) Fold both ends of tent toward center, first making a three and one half foot fold, and succeeding folds of six foot each until folded dimension is six by eighteen feet.
- (14) Fold tent in half (view B, figure 4-29) then fold long length in half once more until it measures four and one half by six foot.
- (15) Place folded tent in cover; then close and fasten cover securely.
- (16) Gather all tent pins and tie them in bundles of the same lengths, then bundle jointed poles for ease in handling.

NOTE

The large tent is now ready for movement to a nearby new worksite. When movement is more distant, tent may be palletized for ease in handling.

4-36. Packing for Shipment or Limited Storage.

- a. Pitch, strike and fold tent in the manner described in this manual. Do not try to take shortcuts unless you are sure no damage will be done. To protect the top of the tent during handling and in storage, fold the tent so that the sidewalls rather than the top of the tent will be exposed.
- b. Observe the utmost care when pitching and striking tent, making sure the material does not tear on protruding pins, overhanging branches, or other objects.
- c. Never drag tent along the ground or floor.
- d. Use all the necessary parts and accessories for the tent and use them for their intended purpose.
- e. Pack tent carefully for shipment. Some tents are issued complete with bag or cover. In this case, carry tent in bag or cover. When no bag or cover is issued, the tent is usually received wrapped in burlap. Save this material for rewrapping when the tent has to be moved again. Normally, tent should never be transported without a covering of some kind.
- f. Pack pins and poles separately from the tent itself except when tent instructions require them to be packed with the tent.

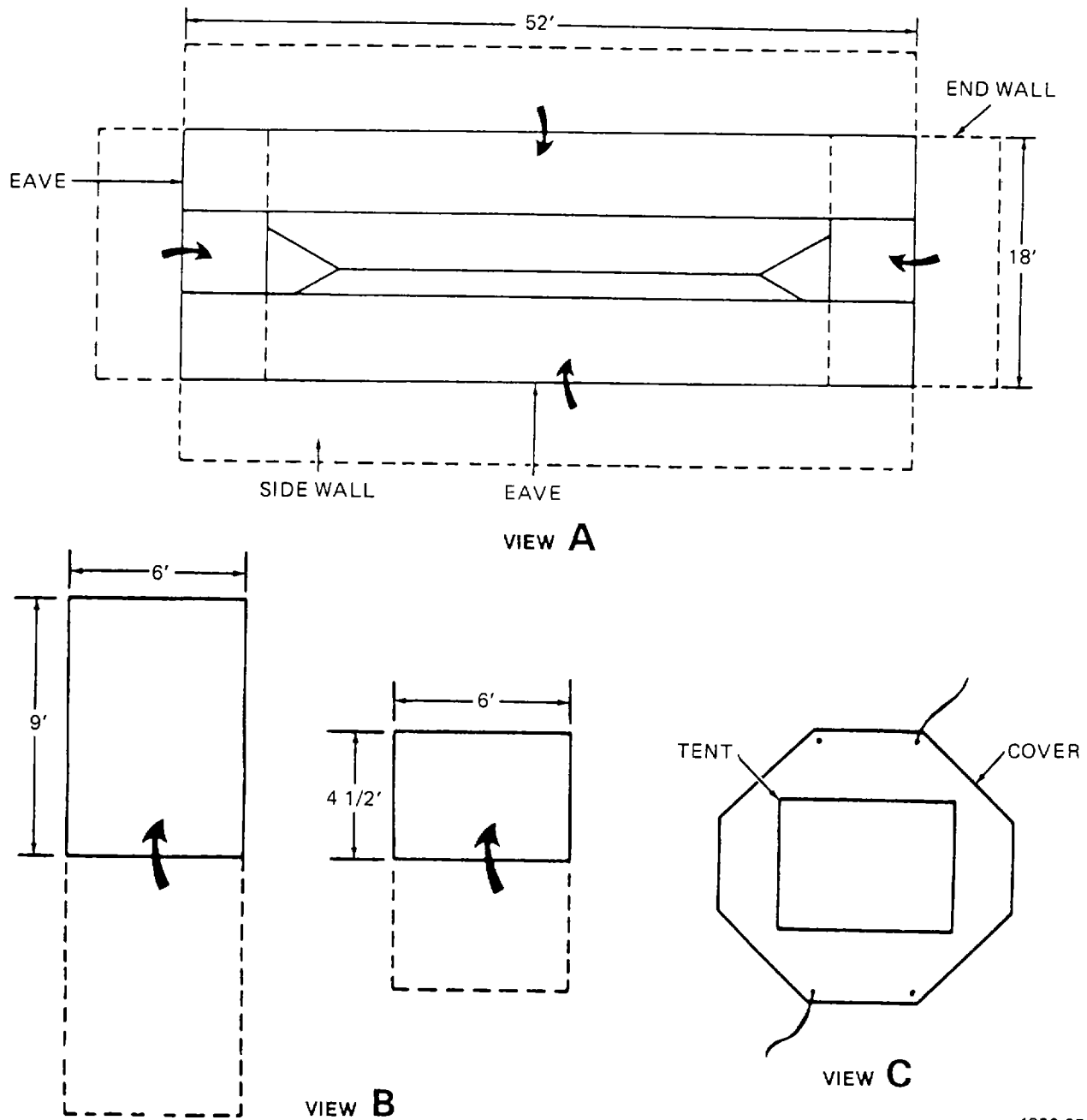

4890-052

Figure 4-29. Folding the Large Tent.

g. To prevent mildew, follow these rules.

- (1) Never fold or roll tent when wet. Even if it is only damp from dew, it will mildew when stored. Ensure that the seams and edges of the tent, especially the bottom edge of the sod cloth, are dry.
- (2) When storing or transporting, keep pins, and poles separate from tent, except when tent instructions require them to be packed with the tent. In the case of the latter, make sure the pins and poles are cleaned and dried before being placed with the tent.

- (3) Before storing, dry tent by hanging it up off the ground in bright sunlight. A tent dried on the ground or left hanging outdoors after sundown might absorb enough dampness for mildew to start. When necessary, a tent can be dried indoors. When drying indoors, hang the tent in a well ventilated place, high enough to permit the tent to be suspended off the floor.
- (4) Do not drag tents along the ground or permit it to come in contact with the ground while in storage.
- (5) When storing tent, stack it on frames supported by 2-by-4 inch lumber. If the floor is hard surfaced or wooden, the tent should be at least 4 inches from the floor. If the floor is earthen, the tent should be at least 8 inches from the ground.
- (6) When dampness in the atmosphere is prevalent, fumes should be used between each course to permit circulation of air between the blocks. The blocks should be separated and reduced to a minimum number of courses to permit passage of air on all four sides.
- (7) When tent is to be stacked near ventilators or openings that may admit moisture, protect tent by packing it in bag or waterproof covering.
- (8) Do not place tent received from the field in bags until tent is thoroughly dried and all dirt removed by stiff brushes. If any visible signs of mildew are present, hang tent in open air, preferably in the sun.
- (9) Give priority of issue to tents that have been in storage the longest. To prevent issue of newly stored tent before older stocks are exhausted, blocks should be marked in accordance with length of time tent has been in storage.
- (10) When tent is stored in open sheds or in tents, it should be stacked well away from the sides and ends of shelter (preferably about 2 feet), and items not affected by moisture should be stacked between tents.
- (11) Withdraw from storage any tent found to be infected with mildew. Brush with a stiff brush, allow to dry thoroughly, and issue immediately to installations where driest atmospheric conditions prevail. If there is no opportunity for immediate issue, segregate infected tent from sound tents to prevent contamination. Tent which has become unserviceable and cannot be repaired at the unit level of maintenance shall be shipped to direct support level of maintenance for repair and return to user. If items are uneconomically repairable in accordance with TB 750-97-27, they shall be salvaged.

4-37. Administrative Storage.

- a. Placement of equipment in administrative storage should be for short periods of time when a shortage of maintenance effort exists. Items should be in mission readiness within 24 hours or within the time factors as determined by the directing authority. During the storage period appropriate maintenance records will be kept.
- b. Before placing equipment in administrative storage, current maintenance services and Equipment Serviceable Criteria (ESC) evaluations should be completed, shortcomings and deficiencies should be corrected, and all Modification Work Orders (MWO's) should be applied.
- c. Storage site selection. Inside storage is preferred for items selected for administrative storage. If inside storage is not available, trucks, vans, conex containers and other containers may be used.

CHAPTER 5

DIRECT SUPPORT MAINTENANCE INSTRUCTIONS

	Page
OVERVIEW.....	5-1
SECTION I. Repair Parts, Special Tools, TMDE and Support Equipment	5-1
SECTION II. Troubleshooting.....	5-1
SECTION III. Direct Support Maintenance Procedures	5-2

OVERVIEW

This chapter contains DS maintenance and troubleshooting.

Section I. REPAIR PARTS, SPECIAL TOOLS, TMDE AND SUPPORT EQUIPMENT

Paragraph	Page
5-1 Common Tools	5-1
5-2 Special Tools, TMDE and Support Equipment	5-1
5-3 Repair Parts	5-1

5-1. **Common Tools.** There are no common tools or tool kits listed in Section III of Appendix B, Maintenance Allocation Chart.

5-2. **Special Tools, TMDE and Support Equipment.** There are no special tools or equipment needed to maintain the tents.

5-3. **Repair Parts.** Repair parts for direct support maintenance of the tents are listed and illustrated in TM 10-8340-211-23P.

Section II. TROUBLESHOOTING

Paragraph	Page
5-4 Troubleshooting	5-1

5-4. **Troubleshooting.** There is no troubleshooting at direct support. For unit troubleshooting, see Chapter 4, Section IV

Section III. DIRECT SUPPORT MAINTENANCE PROCEDURES

Paragraph

5-5	General	5-2
5-6	Tent Body	5-3
5-7	Slide Fasteners and Hardware	5-4
5-8	Stovepipe Opening Shield	5-5
5-9	Tent Accessories.....	5-7

5-5. **General.** Direct support maintenance involves more extensive tentage repair procedures than allowed at the unit support level. Repairs of tent fabric greater than 4 inches in length or diameter and major repairs to other tent components are done at direct support maintenance.

5-6. Tent Body (Fabric).

This task covers: Repair

INITIAL SETUP

Tools

Equipment Condition

Repair Kit, Tentage

Tent Folded

Repair.

NOTE

Fabric repairs will consist of panel replacement, large patches, machine sewing of seams, webbing, and chapes for necessary reinforcement. Other repairs will be covered in the following sections.

- (1) *Fabric repairs.*
 - (a) *Preparation for repair.* Prepare the tent or component for repair as directed in FM 10-16.
 - (b) *Method and essential points of inspection.* Inspect essential points of tent and components methodically as directed in FM 10-16.
 - (c) *Repair standards.* Follow the repair standards outlined in FM 10-16 for fabric components.
 - (d) *Final inspection.* After repairs have been completed, make a final inspection paying particular attention to quality and thoroughness of repair action. Check all points outlined in FM 10-16.

5-7. Slide Fastener and Hardware.

This task covers: Repair

INITIAL SETUP

Tools

Equipment Condition

Repair Kit, Tentage

Tent Folded

Repair.

NOTE

Hardware and fasteners will be obtained from salvaged tents or components when possible, but may also be obtained from stock room when available, or by requisition.

- (1) *Slide fastener.* Repair or replace slide fasteners as directed in TM 9-2865.
- (2) *Hardware.* Replace D-rings, round rings, snaps, triangle hooks, slide loops, end buckles, keepers, thimbles, links, double bar tangles buckles, or other hardware as directed in FM 10-16.

5-8. Stovepipe Opening Shield.

This task covers: **a. Repair** **b. Replace**

INITIAL SETUP

Tools

Equipment Condition

Adhesive MIL-A-46106

Tent Folded

- a. Repair (figure 5-1).

NOTE

Minor repairs to shield of stovepipe opening are made at unit support. Larger repairs or replacement are made as follows:

- (1) *General.* Repairs to shield (1) will be made with adhesive MIL-A-46106, and a patch cut from silicone fabric of an unreparable shield from salvage, as described in 2 below. When shield is beyond repair, replace shield as described in b. below.
- (2) *Repair of stovepipe shield.*
 - (a) Assure that area to be repaired and surface of patch to be applied are clean and dry.
 - (b) Cut patch from a salvaged shield, large enough to extend one inch beyond damaged area in all directions.
 - (c) Apply a heavy solid layer of adhesive MIL-A-46106 on shield, or on patch (not on both) then press the patch in place. Add more adhesive on shield around edges of patch, then add more adhesive on patch at damaged edges of shield (opposite side).

CAUTION

Insure that adhesive is fully cured before tent is folded. During a warm day with low humidity, an adequate cure will be achieved in four hours. On a warm day of high humidity, the cure will require six hours.

- (d) Support stovepipe opening and repaired shield in a manner so that nothing will touch either side of patch until a cure of the adhesive has been achieved.
- b. Replace. When shield has been damaged beyond repair described previously, it will be replaced with one obtained from a salvaged tent, or a new one obtained from stock, as described below.
- (1) Removal.
 - (a) Cut all stitching holding flaps, drip cap, and tie tapes on outside of tent (figure 2-6 or figure 2-10). Retain serviceable component for later installation.

5-8. Stovepipe Opening Shield (cont).

- (b) Cut stitching of binding and tie tape on inside of tent (figure 2-7), retain serviceable components for later installation, then remove and discard damaged shield.
- (2) *Installation.*
 - (a) Position serviceable shield on panel opening inside tent, then position tie tapes and binding and machine sew in place with same type stitch used in original construction.
 - (b) Position flaps, tie tape, and drip cap on outside of tent, then machine sew with same type stitch used in original constructions.
- (3) *Compound coating.* When necessary, fabric repair patches and seams may be coated with compound MIL-C-13295, type 1 (para. 4-19), as a safeguard against mildew or leaks.

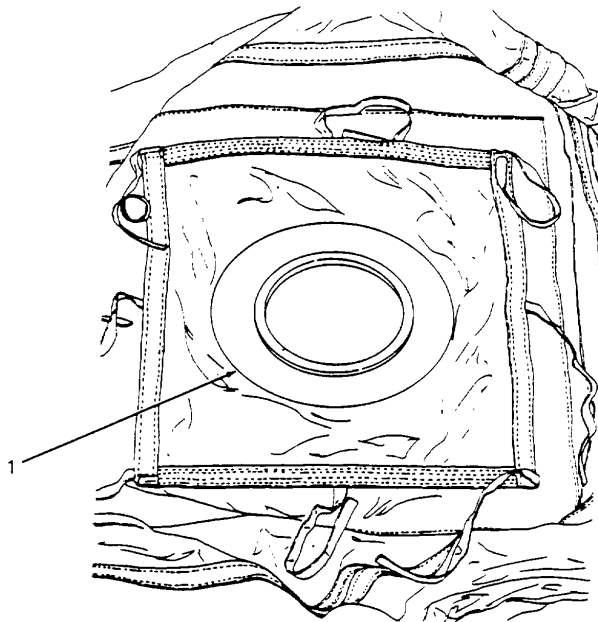

4890-053

Figure 5-1. Stovepipe Opening Shield.

5-9. Tent Accessories.

This task covers: a. **Replace**

INITIAL SETUP

Tools

Equipment Condition

Repair Kit, Tentage

Tent Folded

a. Replace.

NOTE

This paragraph furnishes information for manufacture of cover or liner required. For tent line manufacture, refer to Appendix F.

Cover for medium tent or liner for large tent (figure 5-2), refer to table 5-1 and FM 10-16 to fabricate cover for medium tent or liner for large tent.

Table 5-1. Fabricated Tent Cover or Liner.

Item	Fabricate from NSN	Finished dimension	Remarks
Cover, tent liner	8305-00-170-3903	8 ft. 2 in. x 7 ft.	Install grommets and lines similar to figure 4-3, per FM 10-16.

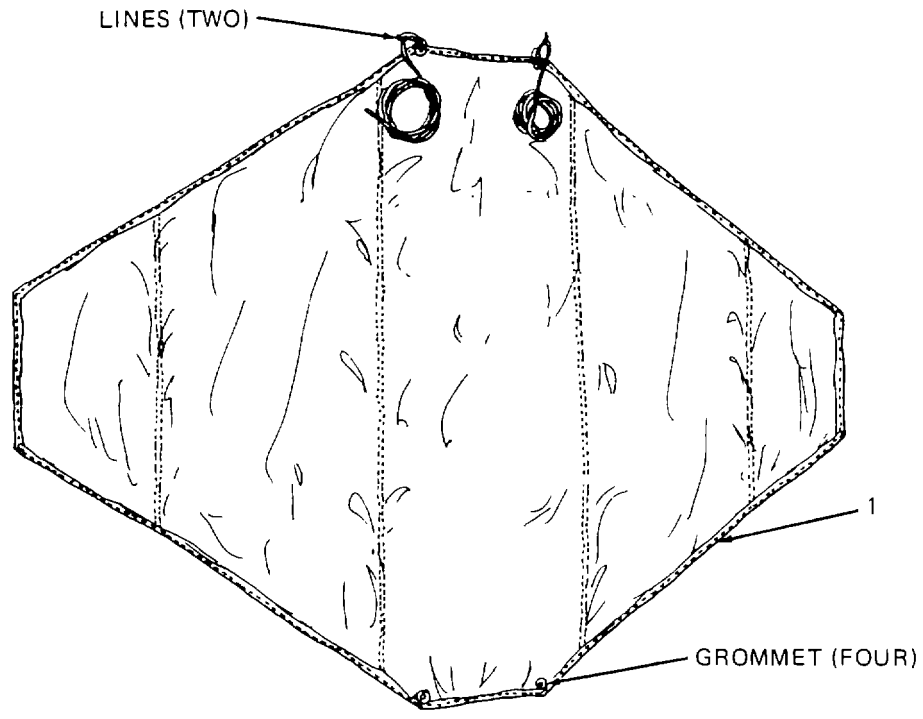

4890-054

Figure 5-2. Cover for Medium Tent or Liner for Large Tent.

APPENDIX A

REFERENCE

A-1. **Scope.** This appendix lists all forms, military specifications, technical manuals and miscellaneous publications referenced in this manual.

A-2. Forms and Records.

Recommended Changes to Publications and blank Forms	DA Form 2028
Equipment Inspection and Maintenance Worksheet	DA Form 2404
Consolidated Index of Army Publications and Blank Forms	DA Pam 25-30
The Army Maintenance Management System (TAMMS)	DA Pam 738-750

A-3. Military Specifications.

Silicone Rubber Adhesive	MIL-A-46106
Type 1, Compound Coating, Mildew, Water and Fire Resistant	MIL-C-13295

A-4. Technical Manuals and Bulletins.

Hand Portable Fire Extinguisher for Army Users	TB 5-4200-200-10
Color Marking and Camouflage Patterns used on Military Equipment	TB 43-014
Operator, Unit and Intermediate Direct Support Repair Parts and Special Tools List	TM 10-8340-211-23P
Heat Space; Radiant Type	TM 10-4500-200-13
Destruction of Army Materiel to Prevent Enemy Use	TM 750-244-3
Administrative Storage	TM 740-90-1
Preservation, Packaging and Packing of Military Supplies and Equipment	TM 38-230-1
Maintenance Forms and Records	TM 38-750
Repair of Slide Fasteners	TM 9-2865
General Repair of Tent Canvas and Webbing	FM 10-16
Maintenance Expenditure Limits for F&C Groups 72, 83, 84, F&C Classes 7210, 8340 and 8400	TB 43-0002-27

APPENDIX B

MAINTENANCE ALLOCATION CHART (MAC)

Section I. INTRODUCTION

B-1. The Army Maintenance System MAC

This introduction provides a general explanation of all maintenance and repair functions authorized at the two maintenance levels under the Two-Level Maintenance System concept.

This MAC (immediately following the introduction) designates overall authority and responsibility for the performance of maintenance functions on the identified end item or component. The application of the maintenance functions to the end item or component shall be consistent with the capacities and capabilities of the designated maintenance levels, which are shown on the MAC in column (4) as:

Field - includes two columns, Unit maintenance and Direct Support maintenance. The Unit maintenance column is divided again into two more subcolumns, C for Operator or Crew and O for Unit maintenance.

Sustainment – includes two subcolumns, General Support (H) and Depot (D).

The tools and test equipment requirements (immediately following the MAC) list the tools and test equipment (both special tools and common tool sets) required for each maintenance function as referenced from the MAC.

The remarks (immediately following the tools and test equipment requirements) contain supplemental instructions and explanatory notes for a particular maintenance function.

B-2. Maintenance Functions

Maintenance functions will be limited to and are defined as follows:

1. Inspect. To determine the serviceability of an item by comparing its physical, mechanical, and/or electrical characteristics with established standards through examination (e.g., by sight, sound, or feel.) This includes scheduled inspection and gagings and evaluation of cannon tubes.
2. Test. To verify serviceability by measuring the mechanical, pneumatic, hydraulic, or electrical characteristics of an item and comparing those characteristics with prescribed standards on a scheduled basis, i.e., load testing of lift devices and hydrostatic testing of pressure hoses.
3. Service. Operations required periodically to keep an item in proper operating condition; e.g., to clean (includes decontaminate, when required), to preserve, to drain, to paint, or to replenish fuel, lubricants, chemical fluids, or gases. This includes scheduled exercising and purging of recoil mechanisms. The following are examples of service functions:
 - a. Unpack. To remove from packing box for service or when required for the performance of maintenance operations.
 - b. Repack. To return item to packing box after service and other maintenance operations.
 - c. Clean. To rid the item of contamination.

- d. Touch up. To spot paint scratched or blistered surfaces.
 - e. Mark. To restore obliterated identification.
4. Adjust. To maintain or regulate, within prescribed limits, by bringing into proper position, or by setting the operating characteristics to specified parameters.
 5. Align. To adjust specified variable elements of an item to bring about optimum or desired performance
 6. Calibrate. To determine and cause corrections to be made or to be adjusted on instruments of test, measuring, and diagnostic equipment used in precision measurement. Consists of comparisons of two instruments, one of which is a certified standard of known accuracy, to detect and adjust any discrepancy in the accuracy of the instrument being compared.
 7. Remove/Install. To remove and install the same item when required to perform service or other maintenance functions. Install may be the act of emplacing, seating, or fixing into position a spare, repair part, or module (component or assembly) in a manner to allow the proper functioning of an equipment or system.
 8. Paint. To prepare and spray color coats of paint so that the ammunition can be identified and protected. The color indicating primary use is applied, preferably, to the entire exterior surface as the background color of the item. Other markings are to be repainted as original so as to retain proper ammunition identification.
 9. Replace. To remove an unserviceable item and install a serviceable counterpart in its place. "Replace" is authorized by the MAC and assigned maintenance level is shown as the third position code of the Source, Maintenance and Recoverability (SMR) code.
 10. Repair. The application of maintenance services, including fault location/troubleshooting, removal/installation, disassembly/assembly procedures and maintenance actions to identify troubles and restore serviceability to an item by correcting specific damage, fault, malfunction, or failure in a part, subassembly, module (component or assembly), end item, or system.

NOTE

The following definitions are applicable to the "repair" maintenance function:

Services. Inspect, test, service, adjust, align, calibrate, and/or replace.

Fault location/troubleshooting. The process of investigating and detecting the cause of equipment malfunctioning; the act of isolating a fault within a system or Unit Under Test (UUT).

Disassembly/assembly. The step-by-step breakdown (taking apart) of a spare/functional group coded item to the level of its least component, that is assigned an SMR code for the level of maintenance under consideration (i.e., identified as maintenance significant).

Actions. Welding, grinding, riveting, straightening, facing, machining, and/or resurfacing.

11. Overhaul. That maintenance effort (service/action) prescribed to restore an item to a completely serviceable/operational condition as required by maintenance standards in appropriate technical publications. Overhaul is normally the highest degree of maintenance performed by the Army. Overhaul does not normally return an item to like new condition.
12. Rebuild. Consists of those services/actions necessary for the restoration of unserviceable equipment to a like new condition in accordance with original manufacturing standards. Rebuild is the highest degree of material maintenance applied to Army equipment. The rebuild operation includes the act of returning to zero those age measurements (e.g., hours/miles) considered in classifying Army equipment/components.

B-3. Explanation of Columns in the MAC, Section II

Column (1) Group Number. Column (1) lists Functional Group Code (FGC) numbers, the purpose of which is to identify maintenance significant components, assemblies, subassemblies, and modules with the Next Higher Assembly (NHA).

Column (2) Component/Assembly. Column (2) contains the names of components, assemblies, subassemblies, and modules for which maintenance is authorized.

Column (3) Maintenance Function. Column (3) lists the functions to be performed on the item listed in column (2). (For a detailed explanation of these functions refer to "Maintenance Functions" outlined above).

Column (4) Maintenance Level. Column (4) specifies each level of maintenance authorized to perform each function listed in column (3), by indicating work time required (expressed as manhours in whole hours or decimals) in the appropriate subcolumn. This work time figure represents the active time required to perform that maintenance function at the indicated level of maintenance. If the number or complexity of the tasks within the listed maintenance function varies at different maintenance levels, appropriate work time figures are to be shown for each level. The work time figure represents the average time required to restore an item (assembly, subassembly, component, module, end item, or system) to a serviceable condition under typical field operating conditions. This time includes preparation time (including any necessary disassembly/assembly time), troubleshooting/fault location time, and quality assurance time in addition to the time required to perform the specific tasks identified for the maintenance functions authorized in the MAC. The system designations for the various maintenance levels are as follows:

Field:

- C Operator or Crew maintenance
- O Unit maintenance
- F Direct Support maintenance

Sustainment:

- L Specialized Repair Activity
- H General Support maintenance
- D Depot maintenance

NOTE

The "L" maintenance level is not included in column (4) of the MAC. Functions to this level of maintenance are identified by work time figure in the "H" column of column (4), and an associated reference code is used in the REMARKS column (6). This code is keyed to the remarks and the SRA complete repair application is explained there.

Column (5) Tools and Equipment Reference Code. Column (5) specifies, by code, those common tool sets (not individual tools), common Test, Measurement and Diagnostic Equipment (TMDE), and special tools, special TMDE and special support equipment required to perform the designated function. Codes are keyed to the entries in the tools and test equipment table.

Column (6) Remarks Code. When applicable, this column contains a letter code, in alphabetic order, which is keyed to the remarks table entries.

B-4. Explanation of Columns in the Tools and Test Equipment Requirements, Section III

Column (1) - Tool or Test Equipment Reference Code. The tool or test equipment reference code correlates with a code used in column (5) of the MAC.

Column (2) - Maintenance Level. The lowest level of maintenance authorized to use the tool or test equipment.

Column (3) - Nomenclature. Name or identification of tool or test equipment.

Column (4) - National Stock Number (NSN). The NSN of the tool or test equipment.

Column (5) - Tool Number. The manufacturer's part number.

B-5. Explanation of Columns in Remarks, Section IV

Column (1) - Remarks Code. The code recorded in column (6) of the MAC.

Column (2) - Remarks. This column lists information pertinent to the maintenance function being performed as indicated in the MAC.

**Section II. MAINTENANCE ALLOCATION CHART FOR
TENT, GENERAL PURPOSE, SMALL**

(1) GROUP NUMBER	(2) COMPONENT/ ASSEMBLY	(3) MAINTENANCE FUNCTION	(4) MAINTENANCE LEVEL					(5) TOOLS AND EQUIPMENT REFERENCE CODE	(6) REMARKS CODE	
			FIELD		SUSTAINMENT					
			UNIT		DIRECT SUPPORT	GENERAL SUPPORT	DEPOT			
			C	O	F	H	D			
00	TENT, GENERAL PURPOSE									
01	TENT BODY AND LINER	Inspect Service Repair Replace	3.0 16.0	0.5 2.0	14.0			1, 2, 3 1 A B		
02	TENT SUPPORT AND ANCHORING EQUIPMENT	Inspect Service Replace	1.0 1.0	1.0				A,B		
03	TENT ACCESSORIES	Inspect Service Repair Replace	0.5 0.5	0.5 0.5	3.0			1, 2, 3 1 A A		
04	HARDWARE AND FASTENING DEVICES	Inspect Service Replace	0.5 0.5	0.5				1		

**Section III. TOOLS AND TEST EQUIPMENT FOR
TENT, GENERAL PURPOSE, SMALL**

(1) TOOL OR TEST EQUIPMENT REFERENCE CODE	(2) MAINTENANCE LEVEL	(3) NOMENCLATURE	(4) NATIONAL STOCK NUMBER	(5) TOOL NUMBER
1	O, F	Repair Kit, Tentage	8340-00-262-5767	
2	O	Adjustable Wrench, 8-inch	5120-00-240-5328	
3	O	Hammer, Hand	5120-01-112-8351	

**Section IV. REMARKS FOR
TENT, GENERAL PURPOSE, SMALL**

(1) REMARKS CODE	(2) REMARKS
A	Repair consists of materials contained in the tentage repair kit authorized at the unit level of maintenance. Refer to direct support maintenance for all rips and holes in tent fabric that are over 4 inches in length or diameter.
B	Direct support maintenance consists of repairs that require machine sewing which is not authorized at the unit maintenance level. Direct support is the lowest level of maintenance for machine repair. Lubricate slide fasteners.

APPENDIX C

COMPONENTS OF END ITEM AND BASIC ISSUE ITEMS LISTS

Section I. INTRODUCTION

C-1. **Scope.**

This appendix lists components of end item and basic Issue Items for the tent to help you Inventory items required for safe and efficient operation.

C-2. **General.**

The Components of End Item and Basic Issue Items Lists are divided Into the following sections:

a. Section II Components of End Item. This listing Is for Informational purposes only, and is not authority to requisition replacements. These Items are part of the end Item, but are removed and separately packaged for transportation or shipment. As part of the end item, these items must be with the end item whenever it Is issued or transferred between property accounts.

b. Section III Basic Issue Items. Not applicable.

C-3. **Explanation of Columns.**

The following provides an explanation of columns found in the tabular listings:

a. Column (1) - Illustration Number (Illus Number). This column Indicates the number of the Illustration in which the item is shown.

b. Column (2) - National Stock Number. Indicates the National Stock Number assigned to the Item and will be used for requisitioning purposes.

c. Column (3) - Description. Indicates the National item name and, if required, a minimum description to identify and locate the item. If item needed differs for different NSN's of this equipment, the NSN is shown under the "Usable On' heading in this column. These codes are identified as:

Code	Used On
APX	8340-00-470-2335
APY	8340-00-482-3963
APZ	8340-00-470-2342

d. Column (4) - Unit of Measure (U/M). Indicates the measure used In performing the actual operational maintenance function. This measure is expressed by a two-character alphabetical abbreviation (e.g., ea, ln, pr). N/A

e. Column (5) Quantity Required (Qty rqr). Indicates the quantity of the item authorized to be used with/on the equipment.

**Section II. INTEGRAL COMPONENTS OF END ITEM FOR NSN 8340-00-470-2335
SMALL GENERAL PURPOSE TENT**

(1) Illus Number	(2) National Stock Number	(3) Description	Usable On Code	(4) U/M	(5) Qty Rqr
	8340-00-753-6570	Tent with Cover	APX	EA	1
	8340-00-261-9749	Pin, Tent, Aluminum: 9 in. long	APX	EA	29
	8340-00-753-6575	Pole, Tent, Telescopic, Aluminum: 3 ft to 7 ft long	APX	EA	8
	8340-00-753-6574	Pole, Tent, Telescopic, Aluminum: 8ft6in.to10ftSin.long	APX	EA	1
	8340-00-262-3698	Tent Liner	APX	EA	1

**Section II. INTEGRAL COMPONENTS OF END ITEM FOR NSN 8340-00-482-3963
MEDIUM GENERAL PURPOSE TENT**

(1) Illus Number	(2) National Stock Number	(3) Description	Usable On Code	(4) U/M	(5) Qty Rqr
	8340-00-543-7787	Tent with Cover	APY	EA	1
	8340-00-188-8400	Pole, Tent, Wood: 17 ft long	APY	EA	1
	8340-00-227-1400	Pole, Tent, Wood: 10 ft 3 in. long	APY	EA	2
	8340-00-188-8405	Pole, Tent, Wood: 5 ft 8 in long	APY	EA	10
	8340-00-188-8406	Pole, Tent, Wood: 6 ft 2 in. long	APY	EA	4
	8340-00-261-9750	Pin, Tent, Wood: 16 in. long	APY	EA	48
	8340-00-261-9751	Pin, Tent, Wood: 24 in. long	APY	EA	28
	8340-00-252-2293	Line, Tent Manilla Ridge Guy Line, 5/16 in. 50 ft long	APY	EA	2
	8340-00-262-2402	Tent Liner	APY	EA	1

**Section II. INTEGRAL COMPONENTS OF END ITEM FOR NSN 8340-00-482-3963
MEDIUM GENERAL PURPOSE TENT**

(1) Illus Number	(2) National Stock Number	(3) Description	Usable On Code	(4) U/M	(5) Qty Rqr
	8340-00-262-2397	Cover (as separate item)	APY	EA	1
	8340-00-782-3396*	Pole, Tent, Aluminum: 17 ft long	APY	EA	1
	8340-00-782-3394*	Pole, Tent, Aluminum: 10 ft 3 in. long	APY	EA	2
	8340-00-759-9751*	Pole, Tent, Aluminum: 6 ft 2 in. long	APY	EA	4
	8340-00-759-9747*	Pole, Tent, Aluminum: 5 ft 8 in.	APY	EA	10

*There are lightweight aluminum poles for the general purpose tent in the supply system. Users must make a trade-off between lesser weight and increased cost when purchasing these poles.

**Section II. INTEGRAL COMPONENTS OF END ITEM FOR NSN 8340-00-470-2342
LARGE GENERAL PURPOSE TENT**

(1) Illus Number	(2) National Stock Number	(3) Description	Usable On Code	(4) U/M	(5) Qty Rqr
	8340-00-285-5596	Tent with Cover	APZ	EA	1
	8340-00-188-8411	Pole, Tent, Wood: 12 ft 3 in. long	APZ	EA	4
	8340-00-188-8405	Pole, Tent, Wood: 5 ft 8 in. long	APZ	EA	12
	8340-00-188-8406	Pole, Tent, Wood: 6 ft 2 in. long	APZ	EA	4
	8340-00-261-9750	Pin, Tent, Wood: 16 in. long	APZ	EA	68
	8340-00-261-9751	Pin, Tent, Wood: 24 in. long	APZ	EA	32
	8340-00-252-2293	Line, Tent Manilla Ridge Guy, Line, 5/16 in. 50 ft long	APZ	EA	2
	8340-00-285-8432	Cover (as separate item)	APZ	EA	1
	8340-00-285-5033	Tent Liner	APZ	EA	1

Section III. BASIC ISSUE ITEMS

Not Applicable

APPENDIX D

ADDITIONAL AUTHORIZATION LIST

Section I. INTRODUCTION

D-1. Scope.

This appendix lists additional items you are authorized for the support of the tent.

D-2. General.

This list identifies items that do not have to accompany the tent and that do not have to be turned in with it. These items are all authorized to you by CTA, MTOE, TDA, or JTA.

D-3. Explanation of Listing.

National stock numbers, descriptions, and quantities are provided to help you identify and request the additional items you require to support this equipment. The items are listed in alphabetical sequence by item name under the type document (i.e., CTA, MTOE, TDA, or JTA) which authorizes the item(s) to you.

**ADDITIONAL AUTHORIZATION LIST FOR NSN 8340-00-470-2335
 SMALL GENERAL PURPOSE TENT**

National Stock Number	Description	Usable on Code	U/M	Qty Auth
5120-00-926-7116	Mallet, Wood	N/A	EA	2
8340-00-262-5767	Repair Kit, Tentage	N/A	EA	1

**ADDITIONAL AUTHORIZATION LIST FOR NON 8340-00-482-3963
 MEDIUM GENERAL PURPOSE TENT**

National Stock Number	Description	Usable on Code	U/M	Qty Auth
5120-00-926-7116	Mallet, Wood	N/A	EA	2
8340-00-262-5767	Repair Kit, Tentage	N/A	EA	1

ADDITIONAL AUTHORIZATION LIST FOR NSN 8340-00-470-2342
LARGE GENERAL PURPOSE TENT

National Stock Number	Description	Usable on Code	U/M	Qty Auth
5120-00-926-7116	Mallet, Wood	N/A	EA	2
8340-00-262-5767	Repair Kit, Tentage	NIA	EA	1

APPENDIX E

EXPENDABLE/DURABLE SUPPLIES AND MATERIALS LIST

Section I. INTRODUCTIONS

E-1. **Scope.** This appendix lists expendable supplies and materials you need to operate and maintain the Tent, General Purpose.

E-2. **Explanation of Columns.**

a. Column (1) - Item Number. This number is assigned to the entry in the listing and is referenced in the narrative instructions to identify the material (e.g., "Use Cloth, Abrasive Item 2, App. D").

b. Column (2) - Level. This column identifies the lowest level of maintenance that requires the listed item. (Enter as applicable).

- C - Operator/Crew
- O - Unit Maintenance
- F - Direct Support Maintenance
- H - General Support Maintenance
- D - Depot Maintenance

c. Column (3) - National Stock Number. This is the National stock number assigned to the item; use it to request or requisition the item.

d. Column (4) - Description. Indicates the Federal item name, and, if required, a description to identify the item.

e. Column (5) - Unit of Measure (U/M). Indicates the measure used in performing the actual maintenance function. This measure is expressed by a two-character alphabetical abbreviation (e.g., ea, in, pr). If the unit of measure differs from the unit of issue, requisition the lowest unit of issue that will satisfy your requirements.

Section II. EXPENDABLE/DURABLE SUPPLIES AND MATERIALS LIST

(1) Item Number	(2) Level	(3) National Stock Number	(4) Description	(5) U/M
1	O	8030-00-281-2346	Compound Coating, Mildew, Water and Fire Resistant 5 gal 11-P-595	on
2			Silicone Rubber Adhesive MIL-A-46106	tu
3			Soap	
4			Brush, Soft-Bristled	
5		8315-00-163-1547	Sailmakers Needle GGG-N-202	pg
6		6850-00-264-9038	Dry Cleaning Solvent, 5 gal P-D-680	on
7		4020-00-262-2019	Nylon Cord, 400 yd. Spool	yd

APPENDIX F

LIST OF MANUFACTURED/FABRICATED TENT LINES AND COVERS

F-1. **General.** This appendix will furnish direct support maintenance personnel with the information necessary for manufacturer of items required for installation of unit maintenance.

F-2. **Tent Lines.** Refer to table F-1 for dimensions and end preparation of tent lines.

Table F-1. Fabricated Tent Lines.

Item	Fabricate from FSN	Diameter	Length	Remarks
Thong, Cotton (for slide fasteners)	8315-262-2784	11/32 w	A/R	Usually 15 in. 1- Manufactured per FM 10-16.
Line, Tent, Comer Guy Line (small tent)	4020-233-6561	7/32 in.	23 ft.	Manufactured per FM 10-1 6.
Line, Tent Door Eave Guy Line (small tent)	4020-233-6561	7/32 in.	24 ft., 6 in.	Manufactured per FM 10-1 6.
Line, Tent, Intermediate Eave Guy Line (small tent)	4020-233-6561	7/32 in.	15 ft., 6 in.	Manufactured per FM 10-16.
Line, Tent, Vestibule Comer Eave Guy Line	4020-233-6561	7/32 in.	15 ft., 6 in.	Manufactured per FM 10-16.
Line, Tent, Vestibule Eave Guy Line	4030-233-6561	7/32 in.	24 ft., 6 in.	Manufactured per FM 10-1 6.
Line, Tent, Corner Eave Guy Line (small tent)	4020-233-6561	7/32 in.	15 ft., 6 in.	Manufactured per FM 10-1 6.

F-3. **Covers for General Purpose Tents.**

- a. Refer to FM 10-16 for repair of tent covers.
- b. The following NSNs may be used to requisition covers for the General Purpose Tents.
 - (1) Cover for small tent, NSN 8340-00-841-4648.
 - (2) Cover for medium tent, NSN 8340-00-262-2397.
 - (3) Cover for large tent, NSN 8340-00-285-8432.

F-4. **Liners for General Purpose Tents.** The following NSNs may be used to requisition liners for the General Purpose Tents.

- a. Liner for Small General Purpose Tent, NSN 8340-00-262-3698.
- b. Liner for Medium General Purpose Tent, NSN 8340-00-262-2402.
- c. Liner for Large General Purpose Tent, NSN 8340-00-285-5033.

By Order of the Secretaries of the Army and Air Force:

CARL E. VUONO
General, United States Army
Chief of Staff

Official:

WILLIAM J. MEEHAN, II
Brigadier General, United States Army
The Adjutant General

LARRY D. WELCH,
General USAF
Chief of Staff

Official:

ALFRED G. HANSEN
General, USAF, Commander, Air Force
Logistics Command

DISTRIBUTION:

To be distributed in accordance with DA Form 12-25E, Operator, Unit and Direct Support Maintenance requirements for Tent, General Purpose, S-M-L (MIL-T-41810, MIL-T-14038, MIL-T-1712).

☆ U.S. GOVERNMENT PRINTING OFFICE : 1996 - 406-421 (52098)

These are the instructions for sending an electronic 2028

The following format must be used if submitting an electronic 2028. The subject line must be exactly the same and all fields must be included; however only the following fields are mandatory: 1, 3, 4, 5, 6, 7, 8, 9, 10, 13, 15, 16, 17, and 27.

From: "Whomever" <whomever@avma27.army.mil>

To: amssbriml@natick.army.mil

Subject: DA Form 2028

1. From: Joe Smith
2. Unit: home
3. Address: 4300 Park
4. City: Hometown
5. St: MO
6. Zip: 77777
7. Date Sent: 19-OCT-93
8. Pub no: 55-2840-229-23
9. Pub Title: TM
10. Publication Date: 04-JUL-85
11. Change Number: 7
12. Submitter Rank: MSG
13. Submitter FName: Joe
14. Submitter MName: T
15. Submitter LName: Smith
16. Submitter Phone: 123-123-1234
17. Problem: 1
18. Page: 2
19. Paragraph: 3
20. Line: 4
21. NSN: 5
22. Reference: 6
23. Figure: 7
24. Table: 8
25. Item: 9
26. Total: 123
27. Text:

This is the text for the problem below line 27.

RECOMMENDED CHANGES TO PUBLICATIONS AND BLANK FORMS For use of this form, see AR 25-30; the proponent agency is ODISC4.						Use Part II (reverse) for Repair Parts and Special Tool Lists (RPSTL) and Supply Catalogs/Supply Manuals (SC/SM).	DATE 21 October 2003
TO: (Forward to proponent of publication or form) (Include ZIP Code) COMMANDER U.S. ARMY TANK-AUTOMOTIVE AND ARMAMENT COMMAND ATTN: AMSTA-LC-CECT 15 KANSAS STREET NATICK, MA 01760-5052						FROM: (Activity and location) (Include ZIP Code) <i>PFC Jane Doe</i> <i>CO A 3rd Engineer BR</i> <i>Ft. Leonardwood, MO 63108</i>	
PART I – ALL PUBLICATIONS (EXCEPT RPSTL AND SC/SM) AND BLANK FORMS							
PUBLICATION/FORM NUMBER TM 10-1670-296-23&P				DATE 30 October 2002	TITLE Unit Manual for Ancillary Equipment for Low Velocity Air Drop Systems		
ITEM NO.	PAGE NO.	PARA-GRAPH	LINE NO. *	FIGURE NO.	TABLE NO.	RECOMMENDED CHANGES AND REASON <i>(Provide exact wording of recommended changes, if possible).</i>	
	0036 00-2				1	<i>In table 1, Sewing Machine Code Symbols, the second sewing machine code symbol should be MD ZZ not MD 22.</i> <i>Change the manual to show Sewing Machine, Industrial: Zig-Zag; 308 stitch; medium-duty; NSN 3530-01-181-1421 as a MD ZZ code symbol.</i>	
<small>*Reference to line numbers within the paragraph or subparagraph.</small>							
TYPED NAME, GRADE OR TITLE Jane Doe, PFC				TELEPHONE EXCHANGE/AUTOVON, PLUS EXTENSION 508-233-4141		SIGNATURE Jane Doe <i>Jane Doe</i>	

TO: (Forward direct to addressee listed in publication) COMMANDER U.S. ARMY TANK-AUTOMOTIVE AND ARMAMENT COMMAND ATTN: AMSTA-LC-CECT 15 KANSAS STREET NATICK, MA 01760-5052	FROM: (Activity and location) (Include ZIP Code) <i>PFC Jane Doe</i> <i>CO A 3rd Engineer BR</i> <i>Ft. Leonardwood, MO 63108</i>	DATE <i>21 October 2003</i>
---	--	---------------------------------------

PART II – REPAIR PARTS AND SPECIAL TOOL LISTS AND SUPPLY CATALOGS/SUPPLY MANUALS

PUBLICATION NUMBER TM 10-1670-296-23&P	DATE 30 October 2002	TITLE Unit Manual for Ancillary Equipment for Low Velocity Air Drop Systems
--	--------------------------------	---

PAGE NO.	COLM NO.	LINE NO.	NATIONAL STOCK NUMBER	REFERENCE NO.	FIGURE NO.	ITEM NO.	TOTAL NO. OF MAJOR ITEMS SUPPORTED	RECOMMENDED ACTION
0066 00-1					4			<i>Callout 16 in figure 4 is pointed to a <u>D-Ring</u>. In the Repair Parts List key for figure 4, item 16 is called a <u>Snap Hook</u>. Please correct one or the other.</i>

SAMPLE

PART III – REMARKS (Any general remarks or recommendations, or suggestions for improvement of publications and blank forms. Additional blank sheets may be used if more space is needed.)

TYPED NAME, GRADE OR TITLE	TELEPHONE EXCHANGE/AUTOVON, PLUS EXTENSION	SIGNATURE
----------------------------	--	-----------

<p align="center">RECOMMENDED CHANGES TO PUBLICATIONS AND BLANK FORMS</p> <p>For use of this form, see AR 25-30; the proponent agency is ODISC4.</p>						Use Part II (reverse) for Repair Parts and Special Tool Lists (RPSTL) and Supply Catalogs/Supply Manuals (SC/SM).	DATE
TO: (Forward to proponent of publication or form) (Include ZIP Code) COMMANDER U.S. ARMY TANK-AUTOMOTIVE AND ARMAMENT COMMAND ATTN: AMSTA-LC-CECT 15 KANSAS STREET NATICK, MA 01760-5052						FROM: (Activity and location) (Include ZIP Code)	
PART I – ALL PUBLICATIONS (EXCEPT RPSTL AND SC/SM) AND BLANK FORMS							
PUBLICATION/FORM NUMBER TM 10-8340-211-13				DATE 16 September 1990		TITLE Operator, Unit, and Direct Support Maintenance Manual for Tent, General Purpose	
ITEM NO.	PAGE NO.	PARA-GRAPH	LINE NO. *	FIGURE NO.	TABLE NO.	RECOMMENDED CHANGES AND REASON <i>(Provide exact wording of recommended changes, if possible).</i>	
<i>*Reference to line numbers within the paragraph or subparagraph.</i>							
TYPED NAME, GRADE OR TITLE				TELEPHONE EXCHANGE/AUTOVON, PLUS EXTENSION		SIGNATURE	

TO: (Forward direct to addressee listed in publication) COMMANDER U.S. ARMY TANK-AUTOMOTIVE AND ARMAMENT COMMAND ATTN: AMSTA-LC-CECT 15 KANSAS STREET NATICK, MA 01760-5052	FROM: (Activity and location) (Include ZIP Code)	DATE
---	---	-------------

PART II – REPAIR PARTS AND SPECIAL TOOL LISTS AND SUPPLY CATALOGS/SUPPLY MANUALS

PUBLICATION NUMBER TM 10-8340-211-13	DATE 16 September 1990	TITLE Operator, Unit, and Direct Support Maintenance Manual for Tent, General Purpose
---	---------------------------	--

PAGE NO.	COLM NO.	LINE NO.	NATIONAL STOCK NUMBER	REFERENCE NO.	FIGURE NO.	ITEM NO.	TOTAL NO. OF MAJOR ITEMS SUPPORTED	RECOMMENDED ACTION

PART III – REMARKS (Any general remarks or recommendations, or suggestions for improvement of publications and blank forms. Additional blank sheets may be used if more space is needed.)

TYPED NAME, GRADE OR TITLE	TELEPHONE EXCHANGE/AUTOVON, PLUS EXTENSION	SIGNATURE
----------------------------	--	-----------

RECOMMENDED CHANGES TO PUBLICATIONS AND BLANK FORMS						Use Part II (reverse) for Repair Parts and Special Tool Lists (RPSTL) and Supply Catalogs/Supply Manuals (SC/SM).	DATE
For use of this form, see AR 25-30; the proponent agency is ODISC4.							
TO: (Forward to proponent of publication or form) (Include ZIP Code) COMMANDER U.S. ARMY TANK-AUTOMOTIVE AND ARMAMENT COMMAND ATTN: AMSTA-LC-CECT 15 KANSAS STREET NATICK, MA 01760-5052						FROM: (Activity and location) (Include ZIP Code)	
PART I – ALL PUBLICATIONS (EXCEPT RPSTL AND SC/SM) AND BLANK FORMS							
PUBLICATION/FORM NUMBER TM 10-8340-211-13				DATE 16 September 1990		TITLE Operator, Unit, and Direct Support Maintenance Manual for Tent, General Purpose	
ITEM NO.	PAGE NO.	PARA-GRAPH	LINE NO. *	FIGURE NO.	TABLE NO.	RECOMMENDED CHANGES AND REASON <i>(Provide exact wording of recommended changes, if possible).</i>	
<i>*Reference to line numbers within the paragraph or subparagraph.</i>							
TYPED NAME, GRADE OR TITLE				TELEPHONE EXCHANGE/AUTOVON, PLUS EXTENSION		SIGNATURE	

TO: (Forward direct to addressee listed in publication) COMMANDER U.S. ARMY TANK-AUTOMOTIVE AND ARMAMENT COMMAND ATTN: AMSTA-LC-CECT 15 KANSAS STREET NATICK, MA 01760-5052	FROM: (Activity and location) (Include ZIP Code)	DATE
---	---	-------------

PART II – REPAIR PARTS AND SPECIAL TOOL LISTS AND SUPPLY CATALOGS/SUPPLY MANUALS

PUBLICATION NUMBER TM 10-8340-211-13	DATE 16 September 1990	TITLE Operator, Unit, and Direct Support Maintenance Manual for Tent, General Purpose
---	---------------------------	--

PAGE NO.	COLM NO.	LINE NO.	NATIONAL STOCK NUMBER	REFERENCE NO.	FIGURE NO.	ITEM NO.	TOTAL NO. OF MAJOR ITEMS SUPPORTED	RECOMMENDED ACTION

PART III – REMARKS

(Any general remarks or recommendations, or suggestions for improvement of publications and blank forms. Additional blank sheets may be used if more space is needed.)

TYPED NAME, GRADE OR TITLE	TELEPHONE EXCHANGE/AUTOVON, PLUS EXTENSION	SIGNATURE
----------------------------	--	-----------

RECOMMENDED CHANGES TO PUBLICATIONS AND BLANK FORMS						Use Part II (reverse) for Repair Parts and Special Tool Lists (RPSTL) and Supply Catalogs/Supply Manuals (SC/SM).	DATE
For use of this form, see AR 25-30; the proponent agency is ODISC4.							
TO: (Forward to proponent of publication or form) (Include ZIP Code) COMMANDER U.S. ARMY TANK-AUTOMOTIVE AND ARMAMENT COMMAND ATTN: AMSTA-LC-CECT 15 KANSAS STREET NATICK, MA 01760-5052						FROM: (Activity and location) (Include ZIP Code)	
PART I – ALL PUBLICATIONS (EXCEPT RPSTL AND SC/SM) AND BLANK FORMS							
PUBLICATION/FORM NUMBER TM 10-8340-211-13				DATE 16 September 1990		TITLE Operator, Unit, and Direct Support Maintenance Manual for Tent, General Purpose	
ITEM NO.	PAGE NO.	PARA-GRAPH	LINE NO. *	FIGURE NO.	TABLE NO.	RECOMMENDED CHANGES AND REASON <i>(Provide exact wording of recommended changes, if possible).</i>	
<i>*Reference to line numbers within the paragraph or subparagraph.</i>							
TYPED NAME, GRADE OR TITLE				TELEPHONE EXCHANGE/AUTOVON, PLUS EXTENSION		SIGNATURE	

TO: (Forward direct to addressee listed in publication) COMMANDER U.S. ARMY TANK-AUTOMOTIVE AND ARMAMENT COMMAND ATTN: AMSTA-LC-CECT 15 KANSAS STREET NATICK, MA 01760-5052	FROM: (Activity and location) (Include ZIP Code)	DATE
---	---	-------------

PART II – REPAIR PARTS AND SPECIAL TOOL LISTS AND SUPPLY CATALOGS/SUPPLY MANUALS

PUBLICATION NUMBER TM 10-8340-211-13	DATE 16 September 1990	TITLE Operator, Unit, and Direct Support Maintenance Manual for Tent, General Purpose
---	---------------------------	--

PAGE NO.	COLM NO.	LINE NO.	NATIONAL STOCK NUMBER	REFERENCE NO.	FIGURE NO.	ITEM NO.	TOTAL NO. OF MAJOR ITEMS SUPPORTED	RECOMMENDED ACTION

PART III – REMARKS (Any general remarks or recommendations, or suggestions for improvement of publications and blank forms. Additional blank sheets may be used if more space is needed.)

TYPED NAME, GRADE OR TITLE	TELEPHONE EXCHANGE/AUTOVON, PLUS EXTENSION	SIGNATURE
----------------------------	--	-----------

The Metric System and Equivalents

Linear Measure

1 centimeter = 10 millimeters = .39 inch
 1 decimeter = 10 centimeters = 3.94 inches
 1 meter = 10 decimeters = 39.37 inches
 1 dekameter = 10 meters = 32.8 feet
 1 hectometer = 10 dekameters = 328.08 feet
 1 kilometer = 10 hectometers = 3,280.8 feet

Weights

1 centigram = 10 milligrams = .15 grain
 1 decigram = 10 centigrams = 1.54 grains
 1 gram = 10 decigrams = .035 ounce
 1 dekagram = 10 grams = .35 ounce
 1 hectogram = 10 dekagrams = 3.52 ounces
 1 kilogram = 10 hectograms = 2.2 pounds
 1 quintal = 100 kilograms = 220.46 pounds
 1 metric ton = 10 quintals = 1.1 short tons

Liquid Measure

1 centiliter = 10 milliliters = .34 fl. ounce
 1 deciliter = 10 centiliters = 3.38 fl. ounces
 1 liter = 10 deciliters = 33.81 fl. ounces
 1 dekaliter = 10 liters = 2.64 gallons
 1 hectoliter = 10 dekaliters = 26.42 gallons
 1 kiloliter = 10 hectoliters = 264.18 gallons

Square Measure

1 sq. centimeter = 100 sq. millimeters = .155 sq. inch
 1 sq. decimeter = 100 sq. centimeters = 15.5 sq. inches
 1 sq. meter (centare) = 100 sq. decimeters = 10.76 sq. feet
 1 sq. dekameter (are) = 100 sq. meters = 1,076.4 sq. feet
 1 sq. hectometer (hectare) = 100 sq. dekameters = 2.47 acres
 1 sq. kilometer = 100 sq. hectometers = .386 sq. mile

Cubic Measure

1 cu. centimeter = 1000 cu. millimeters = .06 cu. inch
 1 cu. decimeter = 1000 cu. centimeters = 61.02 cu. inches
 1 cu. meter = 1000 cu. decimeters = 35.31 feet

Approximate Conversion Factors

<i>To change</i>	<i>To</i>	<i>Multiply by</i>	<i>To change</i>	<i>To</i>	<i>Multiply by</i>
inches	centimeters	2.540	ounce-inches	newton-meters	.007062
feet	meters	.305	centimeters	inches	.394
yards	meters	.914	meters	feet	3.280
miles	kilometers	1.609	meters	yards	1.094
square inches	square centimeters	6.451	kilometers	miles	.621
square feet	square meters	.093	square centimeters	square inches	.155
square yards	square meters	.836	square meters	square feet	10.764
square miles	square kilometers	2.590	square meters	square yards	1.196
acres	square hectometers	.405	square kilometers	square miles	.386
cubic feet	cubic meters	.028	square hectometers	acres	2.471
cubic yards	cubic meters	.765	cubic meters	cubic feet	35.315
fluid ounces	milliliters	29.573	cubic meters	cubic yards	1.308
pints	liters	.473	milliliters	fluid ounces	.034
quarts	liters	.946	liters	pints	2.113
gallons	liters	3.785	liters	quarts	1.057
ounces	grams	28.349	liters	gallons	.264
pounds	kilograms	.454	grams	ounces	.035
short tons	metric tons	.907	kilograms	pounds	2.205
pound-feet	newton-meters	1.356	metric tons	short tons	1.102
pound-inches	newton-meters	.11296			

Temperature (Exact)

 °F Fahrenheit temperature $\times \frac{5}{9}$ (after subtracting 32) = Celsius temperature °C

PIN: 028458-000